

Preface	05
Unprecedented change in the automotive world and its potential impact on the supplier industry	06
Four plausible scenarios for the automotive value chain and their implications for the supplier industry	12
The Deloitte Automotive Value Chain Industry Model	20
Investigating specific material cost developments: Selected model deep dives	30
Overall model result overview	45
Transformation paths towards 2025 for the automotive supplier industry	46
From integrated material cost projections to tailor-made transformation strategies for automotive suppliers	63
Conclusion	67
Contacts	68

Preface

Automotive players are facing disruptive times. Many insights, opinions, and recommendations have been voiced on this. Earlier in 2017, we published our views on the drivers that will likely shape the automotive industry over the next decade. We ranked and fused these into four scenario narratives, giving an outline of what the automotive value chain might look like in 2025. Our previous issue primarily highlighted implications for car manufacturers (OEMs). In this next piece we move further down the value chain, in an attempt to shed light on supplier market implications.

We defined a set of four hypotheses as a starting point to our investigation:

- Commonly discussed automotive mega-trends, like connected and autonomous drive or electrification, will lead to significant change in demand for specific vehicle component clusters
- As a result (some) suppliers will face drastically shrinking market volumes, whereas others must be able to manage massive demand increases
- This will result in significant, strategic, operational, financial, transformation demand for many suppliers
- Portfolio and localization strategy definition processes should be supported by a solid market volume projection model taking all these drivers and megatrends into account

We worked towards validating all these hypotheses by developing the Deloitte Automotive Value Chain (AVC) Industry Model, a comprehensive material cost forecasting tool, which gives volume predictions broken down into a vehicle's component clusters. The model shows that 15 out of 19 vehicle component clusters will likely see a decline in market volume (in Germany, NAFTA and China; not considering effects from general inflation or spare parts demand). The biggest losers will be components related to conventional combustion engines, e.g. transmissions dropping up to -36% in volume. Likely winners, especially suppliers with stakes in the fields of electric drivetrains and battery technology, as well as autonomous driving feature development, on the other hand, must prepare to manage and cater for growing demand of up to 15 times their current volume. Regional projections show that while material cost volumes in Germany are facing a general decline, volumes in China will increase due to general strong vehicle sales forecasts.

Our core premise, however, is that scenario-based thinking is the best preparation for dealing with the uncertainties the future automotive industry developments hold. Therefore, we split each of our volume projections along our four scenarios for 2025 and beyond.

By presenting the Deloitte AVC Industry Model now to the broader public, we are

confident that we are bringing valuable support to the table for automotive decision makers when it comes to tackling some of the most burning strategic decisions.

We hope you enjoy reading our insights and thoughts on the future of the automotive value chain and the related supplier markets.

Joe Vitale

Global Automotive Lead
at Deloitte Consulting

Dr Thomas Schiller

Global Automotive Consulting Lead
at Deloitte Consulting

Unprecedented change in the automotive world and its potential impact on the supplier industry

More than ever before, the automotive industry today is in a state of constant pressure: From customers demanding new and costly features – often without showing additional willingness to pay. From regulators rightfully demanding strictest adherence to environmental and safety standards. And also from major tech players with pockets full of cash pushing investment in mobility business models and threatening traditional OEM dominance.

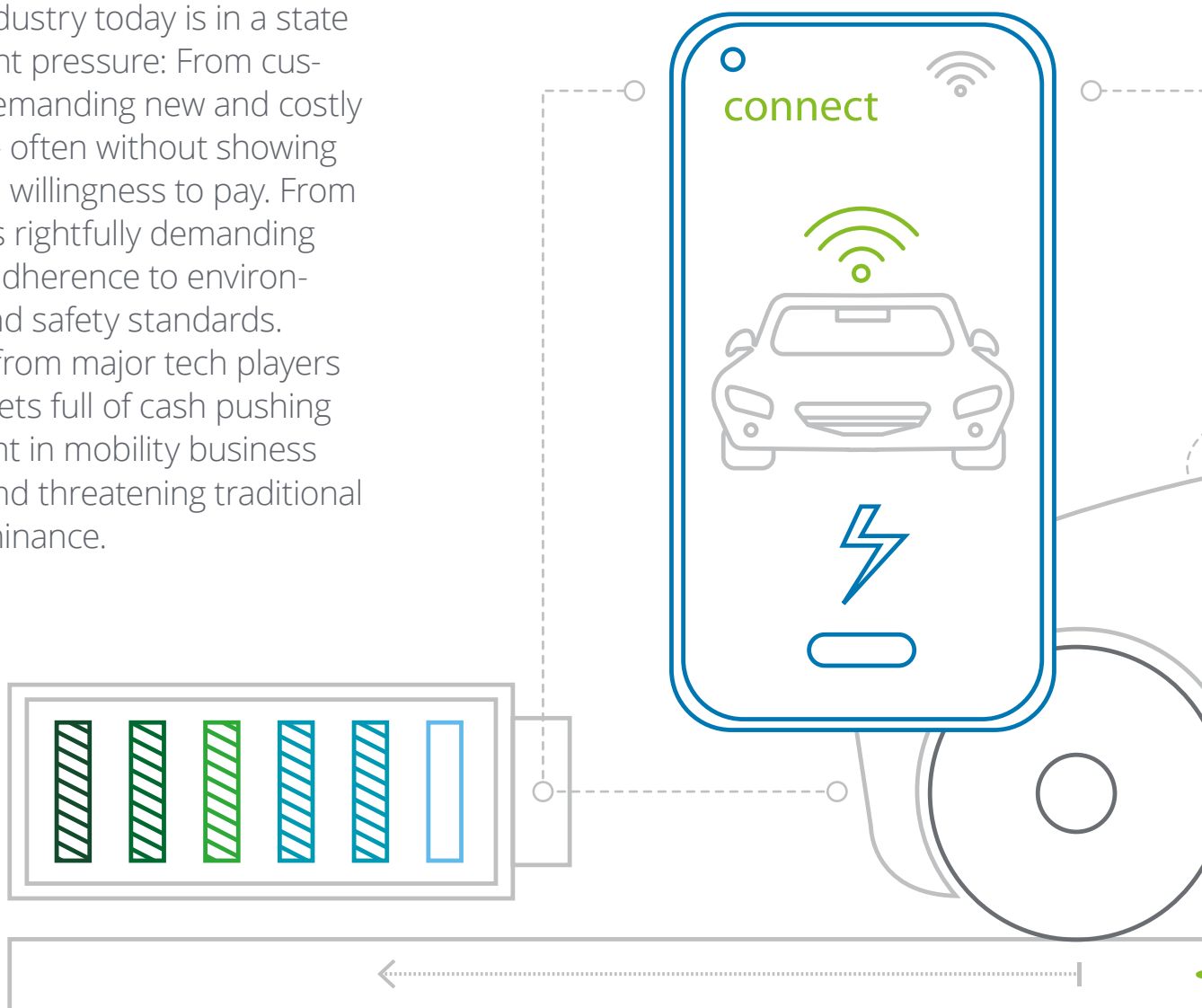

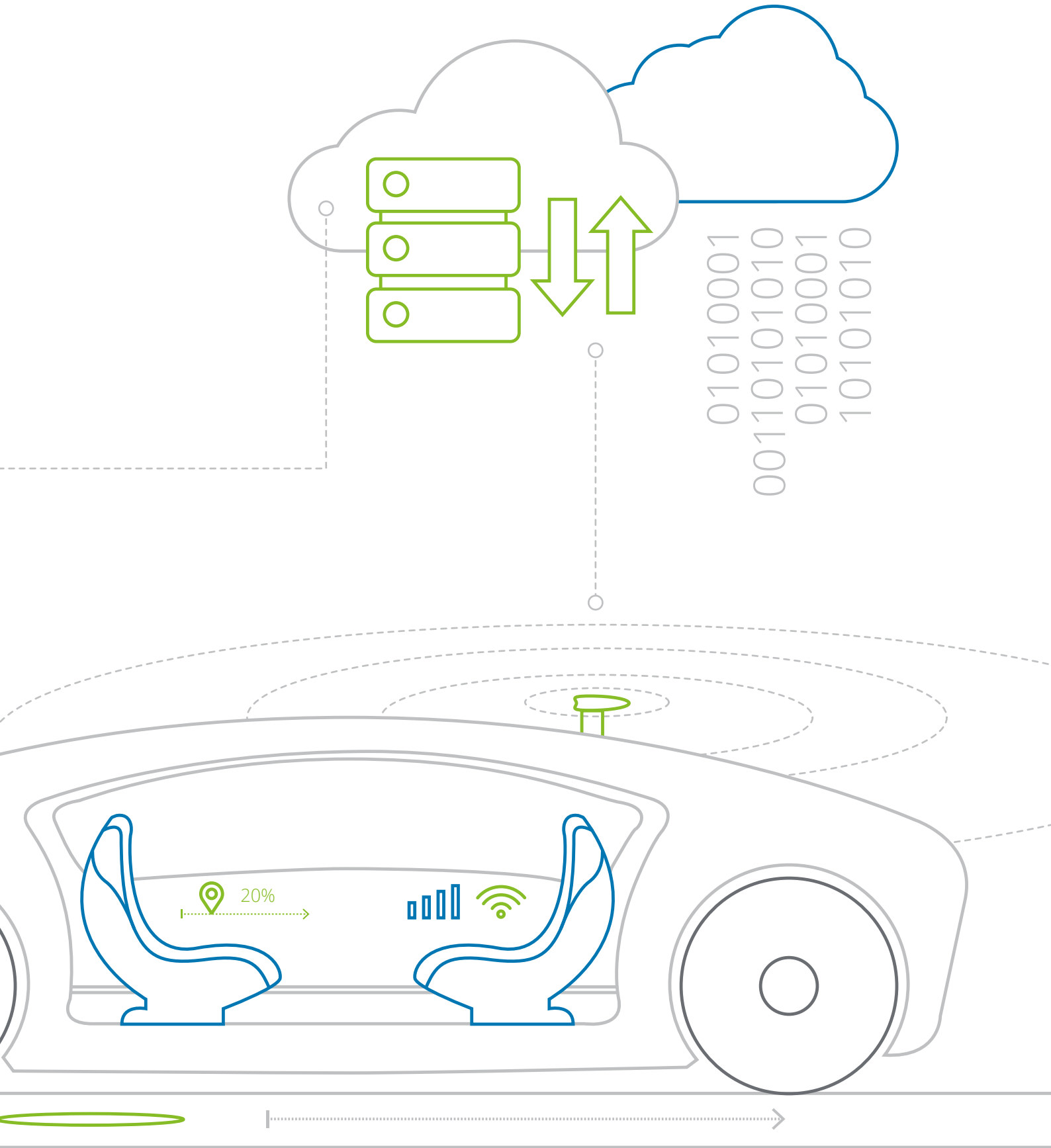

Context

It is well known that the n-tier automotive supply chain is strongly interlinked and ultimately depends heavily on today's seemingly almighty OEMs. The burning question for many decision-makers in the automotive supplier industry is how to REACT to these, potentially existential, changes and threats in the industry landscape. Or, more importantly: How to ACT, with vigor and strategic foresight, and be in a position not only to survive, but to come out on top of the disruptions facing the automotive value chain until 2025 and beyond.

This study focuses on possible developments in supplier market volumes, their underlying trends as well as their implications for decision makers: In the economic and political sphere, at automotive suppliers as well as in OEM development, purchasing, and manufacturing departments. We aim to support automotive leaders in times of great uncertainty by highlighting four quantified scenarios of what the automotive ecosystem might look like in 2025.

Study approach

Following up on our previous issue on the future of the automotive value chain, we based all our considerations on one simple assumption: Future industry developments are hardly ever one-dimensional. Rather, they are based on a multitude of drivers, which almost never develop in a straightforward way. When uncertainty is high, thinking in scenarios can help. So we reviewed the four scenario narratives describing possible states of the automotive value chain in 2025, which were developed for the previous study – together with several top automotive managers, mobility entrepreneurs, researchers, lobbyists, as well as IT and battery developers. We enhanced these scenario narratives with more in-depth insights and discussions around the future of the automotive supplier industry, so we were able to specifically tackle supplier-related concerns (in chapter II).

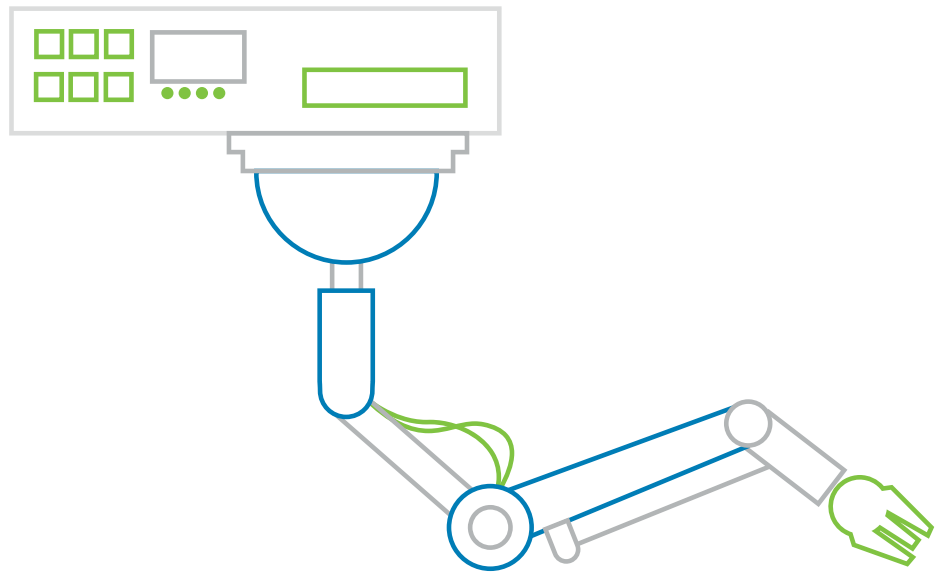

The methodical base for this differentiated analysis was the breakdown of a vehicle into its modules and components: What will electrification, connected and autonomous driving or other user trends change in components used in the car of the future? What are the material cost implications from these trends? And consequently, what impact will all of this have on supplier market volumes and industry structures? We developed an integrated calculation model, summarizing all our thinking and assumptions on future material cost trends – distinguished along the four scenarios outlined above. From this Deloitte AVC Industry Model we derived differentiated material cost market volume forecasts 2025 for vehicles in Germany, China and NAFTA (in chapter III).

Fig. 1 – Questions from selected interviews with automotive suppliers and other industry experts

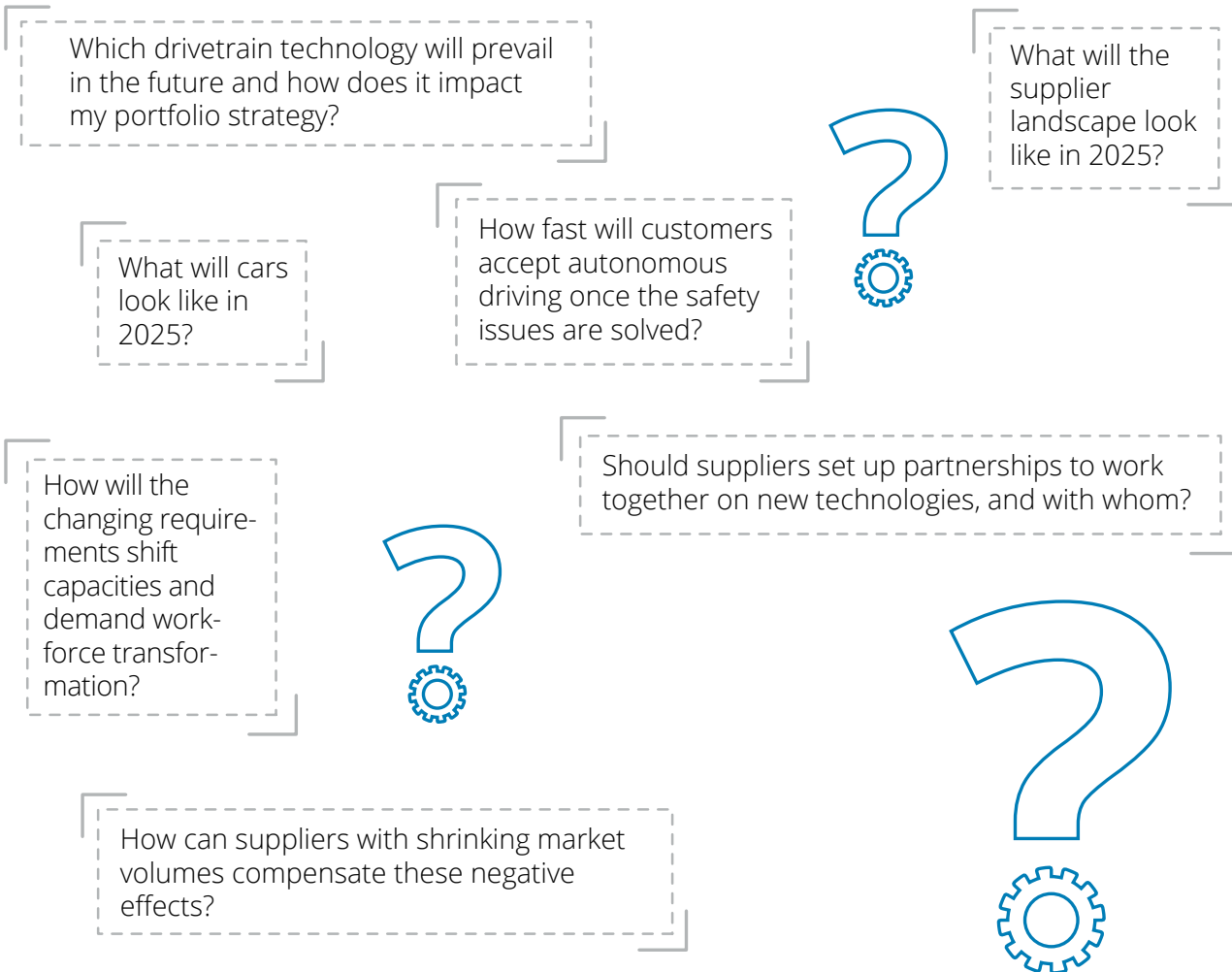

We exemplify our reasoning and model outputs (in chapter IV) along four selected vehicle component clusters where we might see the biggest material cost impact until 2025 – and also face the greatest uncertainty: Interior & infotainment systems, drivetrain technologies (incl. internal combustion engines, transmission and alternative drivetrains), high voltage (HV) batteries & fuel cells, and driver assistance systems. We provide an outline of the key technology trends that are expected to determine the long-term material cost development for each component cluster. In each case, however, we stress the different specifications these technology trends can have, depending on the overall scenario of the automotive world we anticipate.

These and further results from the Deloitte AVC 2025 Industry Model (summarized in chapter V) shed light on substantial, in some cases even burning, needs for change. This study therefore concludes (in chapters VI and VII) with a discussion of implications and recommendations for three spheres of the automotive ecosystem: Political actors and lobby groups when it comes to future industry and employment structures. OEM executives responsible for purchasing, research & development as well as manufacturing. And most importantly: Decision-makers at automotive suppliers facing questions around strategically reassessing product portfolios and potentially restructuring operations.

Joint venture by Valeo and Siemens dedicated to high voltage powertrains starts operation

finanzen.net

ZF: Electric cars could destroy over 100,000 jobs

Handelsblatt

Baidu forges alliances with German auto suppliers

Financial Times

For automakers and suppliers, Silicon Valley is as much a shift in mindset as a location

Forbes

Supplier Brose sees the future of electric cars in China

Süddeutsche Zeitung

The Deloitte
AVC 2025 Industry
Model sheds light on
the substantial, in some
cases burning, need for
change at automotive
suppliers

Fig. 2 – Signposts to the automotive future

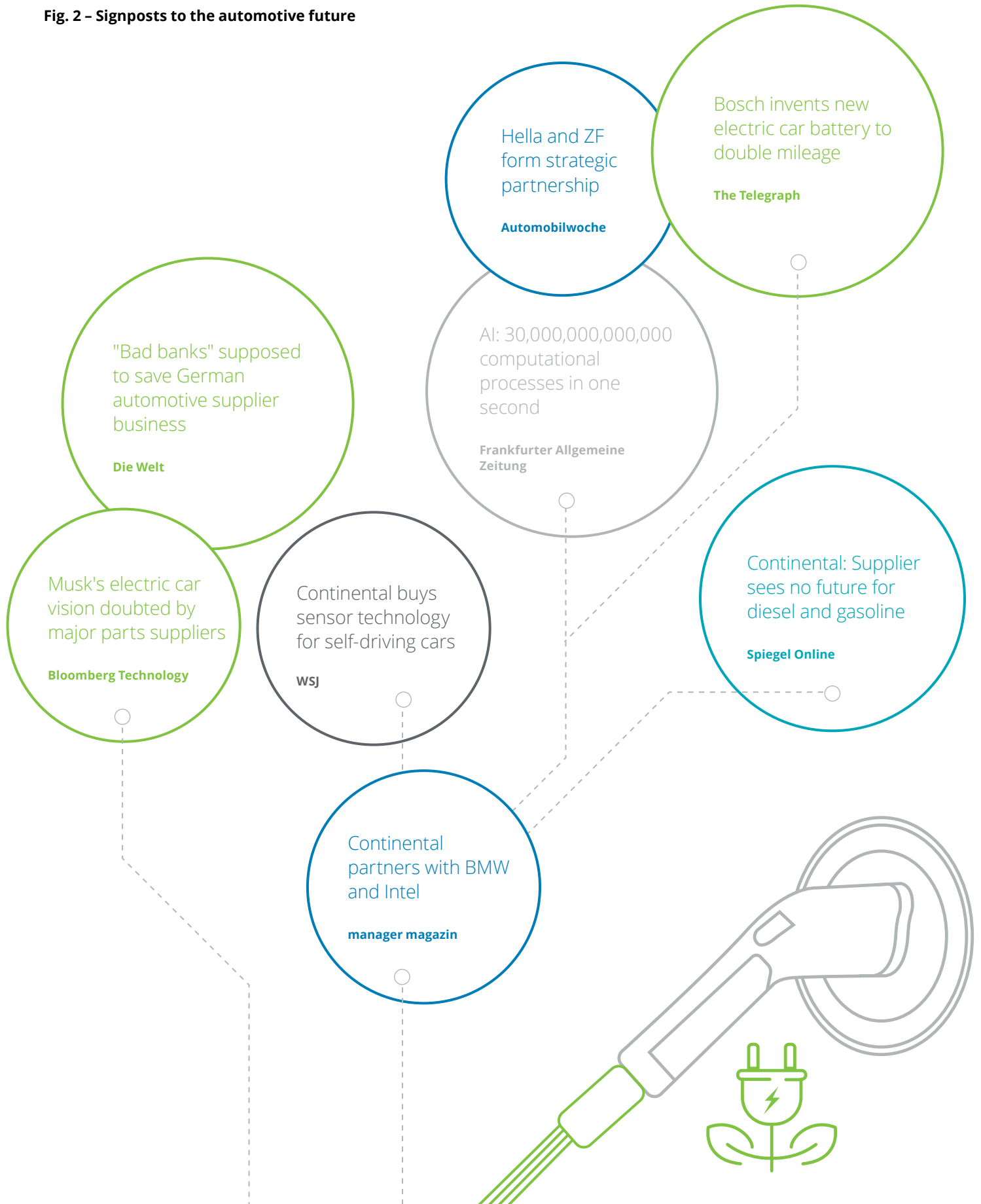

Four plausible scenarios for the automotive value chain and their implications for the supplier industry

Scenario-based thinking can support decision-making under circumstances of high uncertainty. We created four plausible scenarios for automotive suppliers as part of the automotive value chain in 2025.

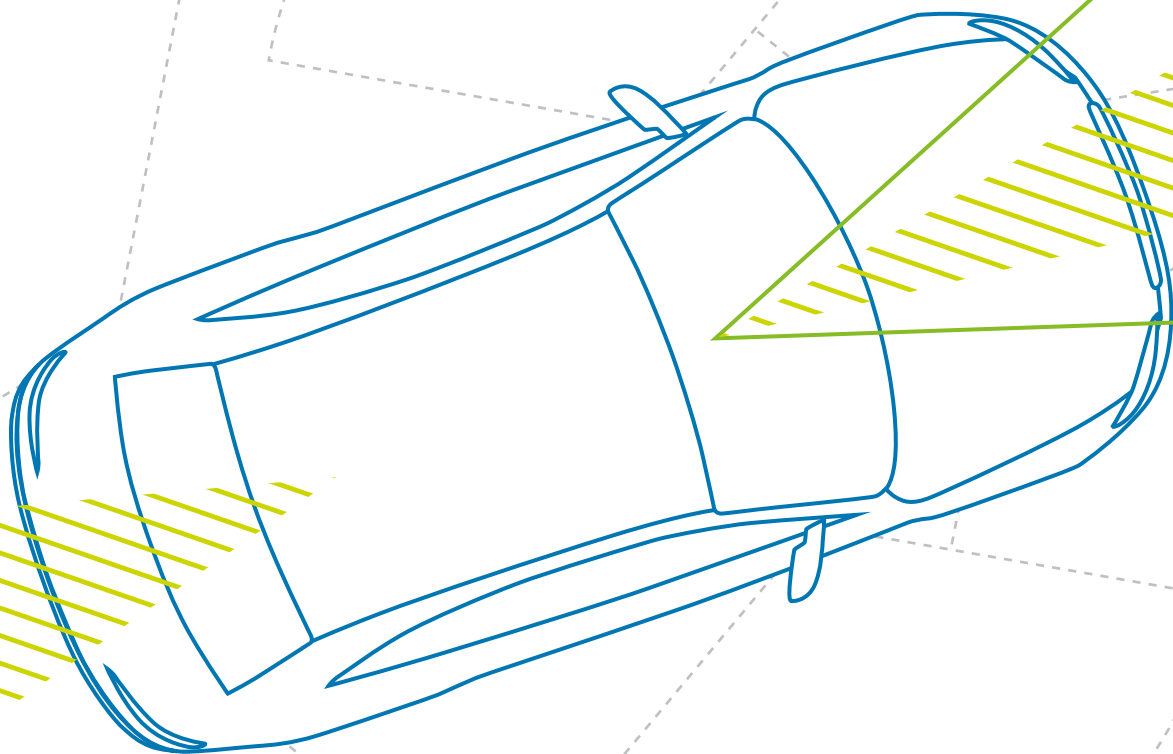



Distinct and meaningful scenarios unfold from drivers where high impact and high uncertainty coincide

In our previous piece "The Future of the Automotive Value Chain – 2025 and beyond" we laid out four quintessential scenarios to describe the future of the automotive industry. Coming from this base, the core assumptions underlying the scenarios were adopted and transferred to the supplier landscape. But before we get to that, a brief recap of the overall 2025 value chain scenarios.

High-influence drivers for the automotive value chain

We analyzed a wide variety of drivers from the areas of social change, technological advancement, economic shifts, environmental trends, and political development. These 60+ drivers were in turn assessed

for their degree of uncertainty and their impact on the future automotive value chain, focusing on the upstream links of the value chain such as R&D, procurement, and manufacturing, and based on extensive research as well as validation interviews and workshops with experts in the respective driver topics. Grouping the drivers according to their impact (on the y-axis) and degree of uncertainty (on the x-axis) highlights the zone of highest interest for scenario building: Distinct and meaningful scenarios always unfold from drivers where high impact and high uncertainty coincide (figure 3). Finally, applying the Deloitte Center for the Long View's proven methods helped formulate four quintessential scenarios:

Fig. 3 – 60+ drivers that will shape the future automotive value chain clustered by impact on the upstream value chain and uncertainty



Fig. 4 – Four scenarios for 2025

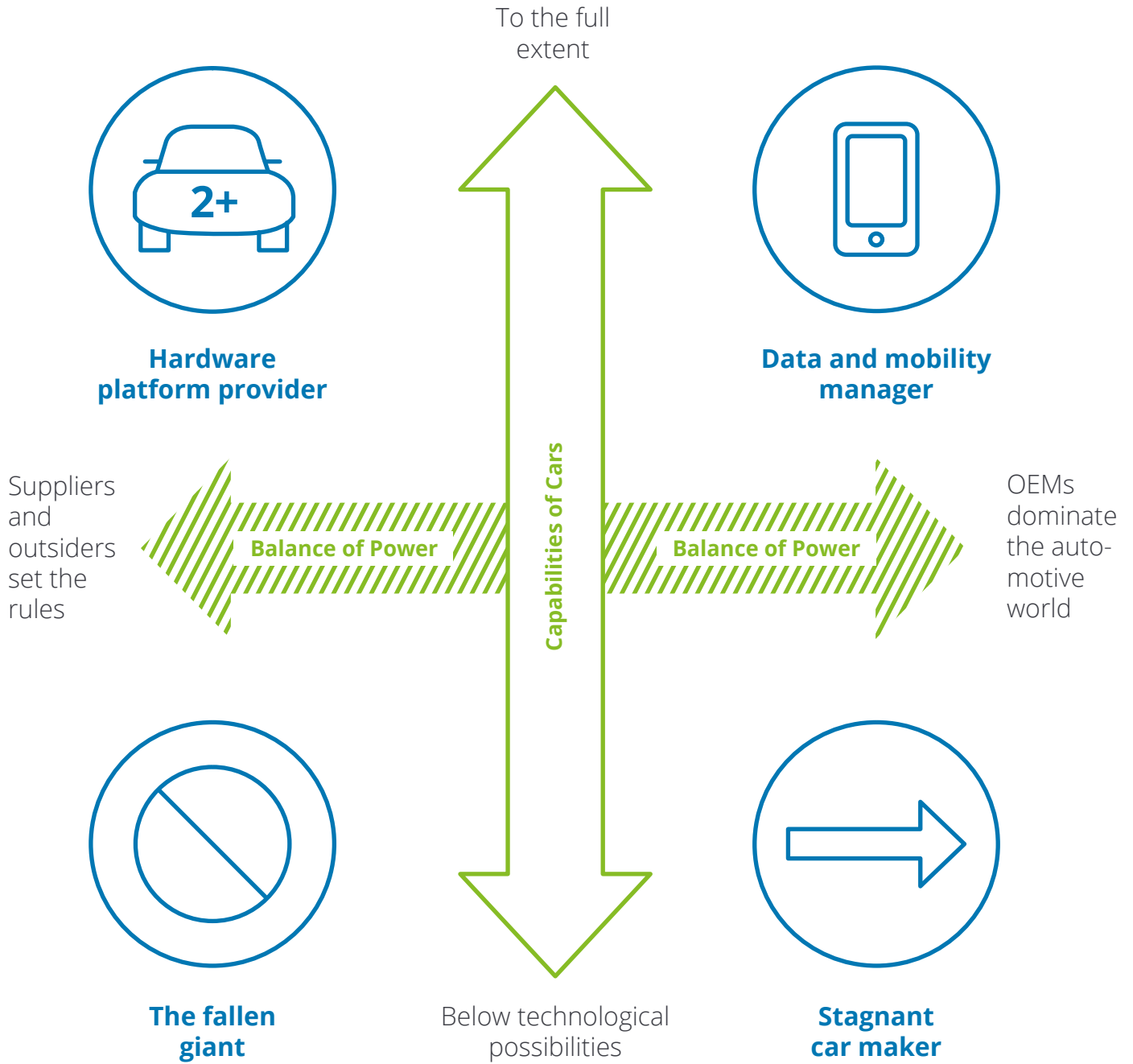

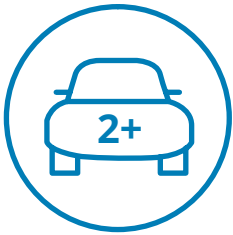

**Scenario 4 –
Hardware platform provider**

IT players have disrupted the automotive value chain. OEMs are now primarily the suppliers of white-label cars to the internet giants. In this world, OEMs can play a relevant role only if they provide a superior platform for ‘infotainment’ and mobility services and/or retain a strong brand image. Since OEMs are not able to fully cash in the revenue potential, the margin per vehicle decreases.

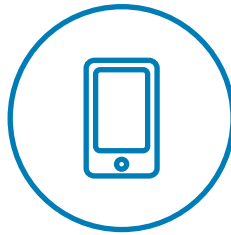

**Scenario 1 –
Data and mobility manager**

In this world, connectivity has become a differentiator. E-mobility (including battery as well as plug-in hybrid electric vehicles, range extenders and fuel cell), autonomous driving, and integrated mobility are a common reality for the broad public. OEMs are able to set the standards and are the dominant players in the automotive industry, offering a rich portfolio of products and services. Innovative automotive outsiders have to play according to the rules set by OEMs. In particular, premium brands and status play a decisive role in consumers’ buying behavior. OEMs offer an attractive workplace for talent.

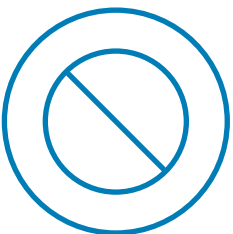

**Scenario 3 –
The fallen giant**

The car is a mere means of transportation and brand attractiveness has diminished. The technology hype has cooled down, which has put an end to the rise of the high-tech car. As mobility has become a commodity, profit margins have decreased and OEMs are focusing on improving processes and cost efficiency. Industry outsiders such as Uber have entered the market and are forging exclusive alliances with suppliers to provide affordable mass mobility. Since private car ownership has decreased, fleet management has become of significant importance for OEMs. New talent is hard to come by, due to the loss in the attractiveness of OEMs.

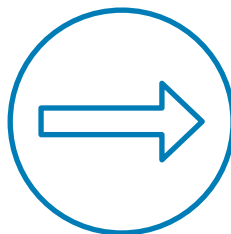

**Scenario 2 –
Stagnant car maker**

Massive lobbying by OEMs has prevented potential new high-tech players from entering the market. However, this defensive strategy has also slowed down technical development, with the result that many potential innovations have not been rolled out to the market, with regulations, for example, limiting the deployment of technology. Dramatic accidents with immature autonomous cars have also resulted in a loss of consumer acceptance.

Specific scenario implications for the supplier industry

Based on these broad scenario narratives, the guiding question for the following chapters is: How will the scenarios impact automotive supplier markets?

In the course of multiple interviews and workshops with automotive experts and researchers, the following supplier-specific considerations were added to each scenario for the automotive value chain in 2025:

In the first scenario, the “Data and mobility manager”, premium suppliers dominate through alliances with OEMs and their software solutions. They will take over a higher number of OEM tasks, e.g. data analysis to improve products and features. Furthermore, through massive investments, suppliers help OEMs to set standards for connected services while ensuring premium quality, which plays a decisive role in this scenario. OEMs demand further services based on platform solutions provided by suppliers. Research and development as well as innovation activities are still driven by rules set by the OEMs.

In the second scenario, the “Stagnant car maker”, the automotive value chain remains mostly unchanged and suppliers keep their traditional role. The hype around connected and autonomous drive technologies is gone and suppliers focus on what they were good at, i.e. incremental innovation along today's vehicle features. As today, suppliers are challenged by OEMs to provide high quality at competitive prices. E-Mobility emerges as an independent business model among OEMs, which leads to a high spend in R&D for this sector among suppliers. In any case, suppliers who focus on innovation in drivetrain technologies are the “winners” in their competitive fields.

How will these value chain scenarios impact today's automotive suppliers?

In the third scenario, “The fallen giant”, industry outsiders like Uber enter the market and forge exclusive alliances with suppliers to provide affordable mass mobility. Suppliers support mass mobility by expanding their service portfolio, e.g. by introducing usage-based pricing schemes for certain components. This also applies to traditional OEM customers, who increasingly focus on fleet management operations and ask for highly durable but affordable spare parts.

In the fourth scenario, the “Hardware platform provider”, suppliers support and form alliances with tech players designing new automotive services/platforms alongside the classic parts supply for OEMs. They become providers of innovative software solutions. The coordination effort between suppliers and third party service providers increases drastically (e.g. for Google traffic control systems). Due to even stronger interlinkage of provided software functionalities, data, and conventional hardware, suppliers gain significant bargaining power.

Fig. 5 – Four scenarios for the automotive value chain in 2025 – adjusted with supplier focus

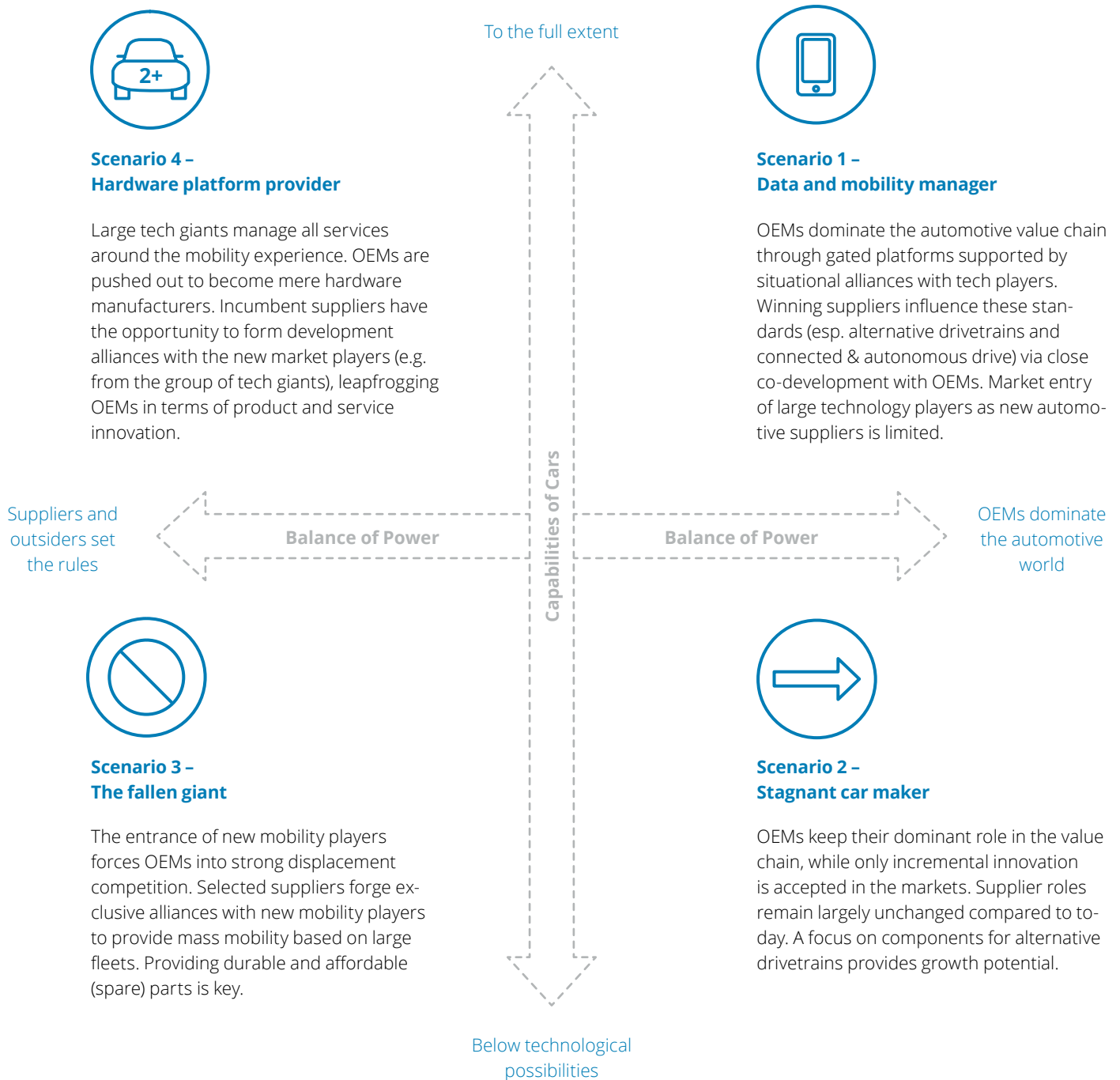

The Deloitte Automotive Value Chain Industry Model

Coming from the overall scenario narratives, we go one step further and use expert assessments and project experience to explore what specific material cost implications might result from these trends and how the market volume for the individual vehicle components will develop until 2025.

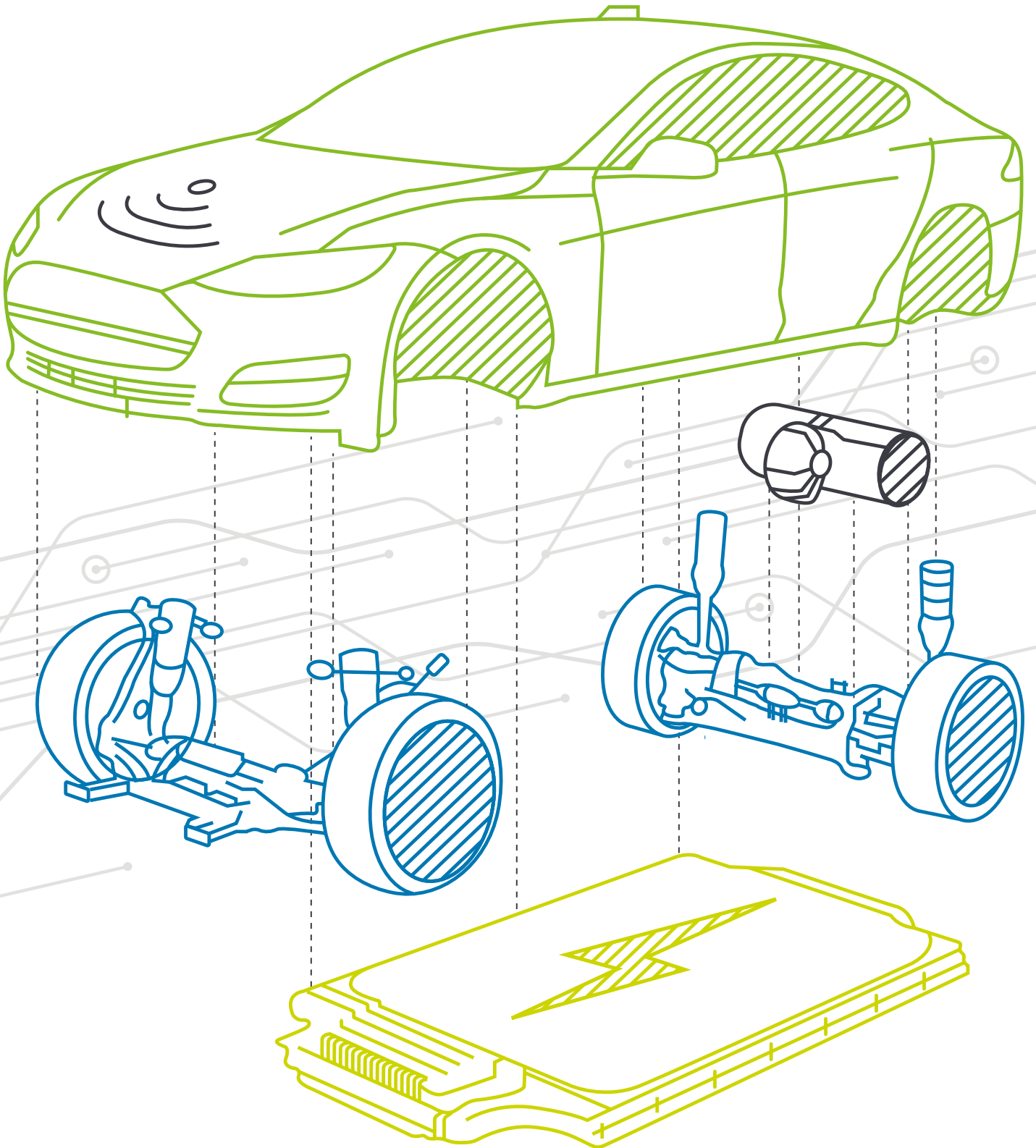

Modelling approach

We started by breaking down a conventional vehicle into its components along 19 clusters. Based on project experience and expert interviews, we set up an average material cost baseline for 2016 of €16k per vehicle (figure 6). This baseline includes material costs for pure hardware components as well as embedded software systems.

As a first step, the Deloitte AVC Industry Model takes the expected material cost development for an average vehicle into account: What is the material cost baseline as per today for an average mid-sized vehicle equipped with an internal combustion engine and limited driver assistance features (level 1 according to the classification of autonomous driving features) [step 1]?

Fig. 6 – Breakdown of vehicle component clusters as a basis for the Deloitte AVC Industry Model

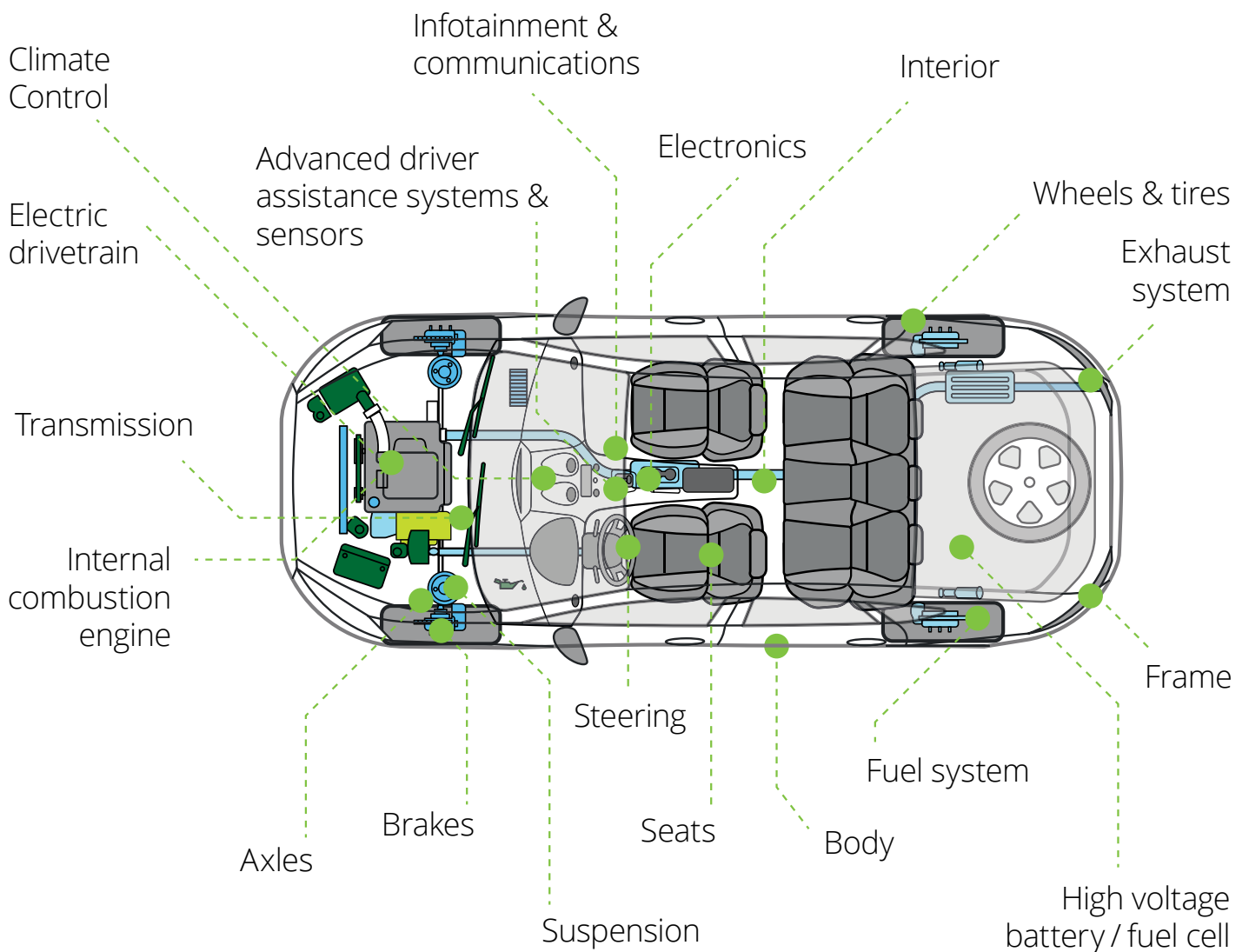

Several sources helped us to model the material cost development of this baseline car towards the year 2025, from extensive research into component-specific technology trends to discussions with industry stakeholders. The guiding questions behind this assessment were: How will technology trends and/or substitution effects of certain materials and parts influence the value of the respective components in the car (not considering effects from general inflation) [step 2]?

As a next step, we distinguished different configuration factors regarding material cost impacts for different types of drivetrains, vehicle segments and levels of autonomous driving. We considered a differentiation between ICE, PHEV, REX, BEV, and FC¹ in terms of drivetrains and adapted the material costs relative to the 2025 baseline car (as mentioned above), e.g. the cost for electronics in a vehicle with a range extender can be around 1.6x higher than in a vehicle with an ICE. The same logic was applied to the vehicle segment configuration factor (micro, compact, medium, premium, luxury) as well as “autonomous drive level” (1–5). In conclusion, each vehicle configuration has its individual material cost calculation [step 3].

As in our previous issue on the future of the automotive value chain, we utilized our Deloitte E-Mobility Model to forecast general vehicle sales until 2025. It provides a scenario-specific forecast distinguishing annual sales of alternative drivetrains and vehicle segments for China, NAFTA, and Germany. Additionally, we included assumptions regarding negative sales impacts from a scenario-specific increase in the sharing economy, i.e. car and ride sharing [step 4]. The multiplication of these vehicle sales forecasts with the above described material cost developments [steps 1–3] provides a first estimation of likely overall market volume developments for each of the 19 component clusters between 2016 and 2025.

Fig. 7 – Modelling approach for the Deloitte Automotive Value Chain Industry model

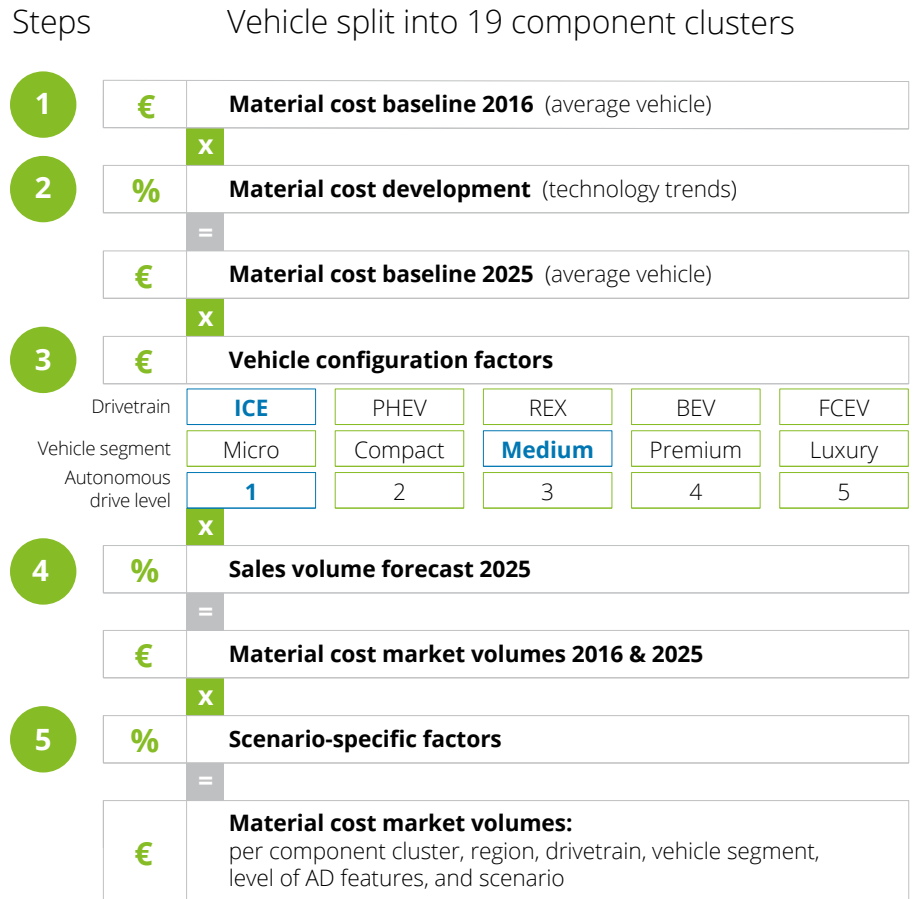

Using a last set of assumptions, we distinguished market volume developments for the four scenarios, as highlighted in chapter II. The key question is:

How does the varying degree to which available technological capabilities are utilized in cars change the material cost outlook? These scenario factors consider, for example, that there will be a higher demand for power supply due to “Electronics” and “Infotainment” in the scenario “Data and Mobility Manager”, as highly connected vehicles are the norm here [step 5]. As an overview, the general approach to the industry model is visualized in figure 7.

¹ICE: Internal Combustion Engine | PHEV: Plugin Hybrid Electric Vehicle | REX: Range Extender | BEV: Battery Electric Vehicle | FC: Fuel Cell

The Deloitte AVC Industry Model fuses and computes all these stated effects and provides a detailed material cost forecast per vehicle component cluster

Model outputs generally show the impact of the stated factors on material cost market volumes for each of the 19 vehicle component clusters, for different regions (Germany, NAFTA, China), powertrains, vehicle segments as well as levels of autonomous drive features – for each of the four Automotive Value Chain scenarios for 2025.

This is shown in figure 8 as an example for the sum of all vehicle modules across key markets (Germany, NAFTA, and China):

- Across all scenarios, efforts to keep material costs down generally lead to a decrease in market volumes. A specific split into winning and losing component clusters in terms of market volume will be provided at the end of this chapter.
- The second, third and fourth pillars show the influence of customer preferences in terms of drivetrain, vehicle segment/size, average level of autonomous driving features as well as other (scenario-specific) sources of vehicle innovation (e.g. in the field of infotainment) assumed per scenario.
- Pillars five and six indicate material cost effects from general vehicle sales developments, with special consideration of negative sales effects from sharing economy, i.e. car and ride sharing. See figure 9 for our specific assumptions for the sharing economy impacts in the markets analyzed.

Fig. 8 – Schematic material cost volume development 2016–2025

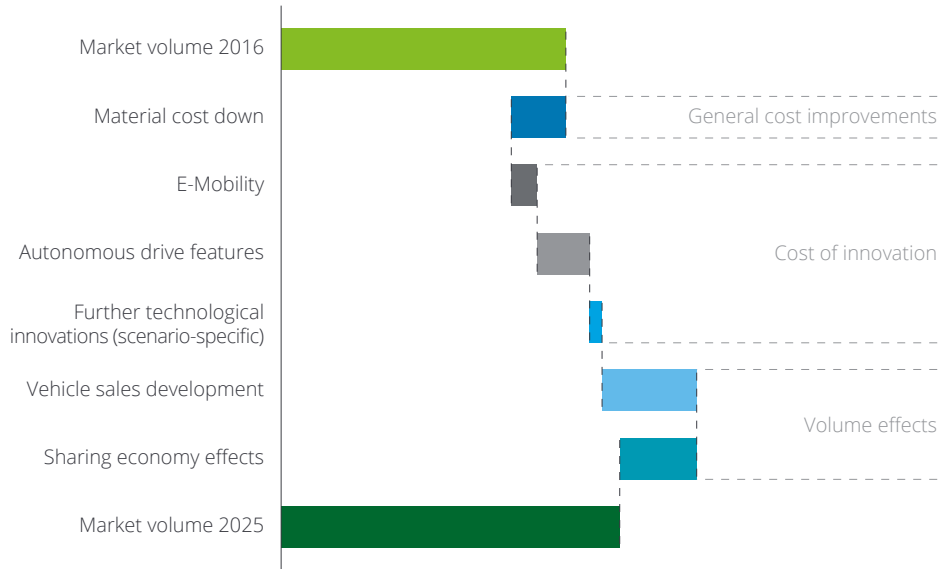

Fig. 9 – Model assumptions regarding potential impact of sharing economy on vehicle sales 2025

On-demand and pay-per-use mobility models might increasingly replace conventional car ownership, especially in urban areas

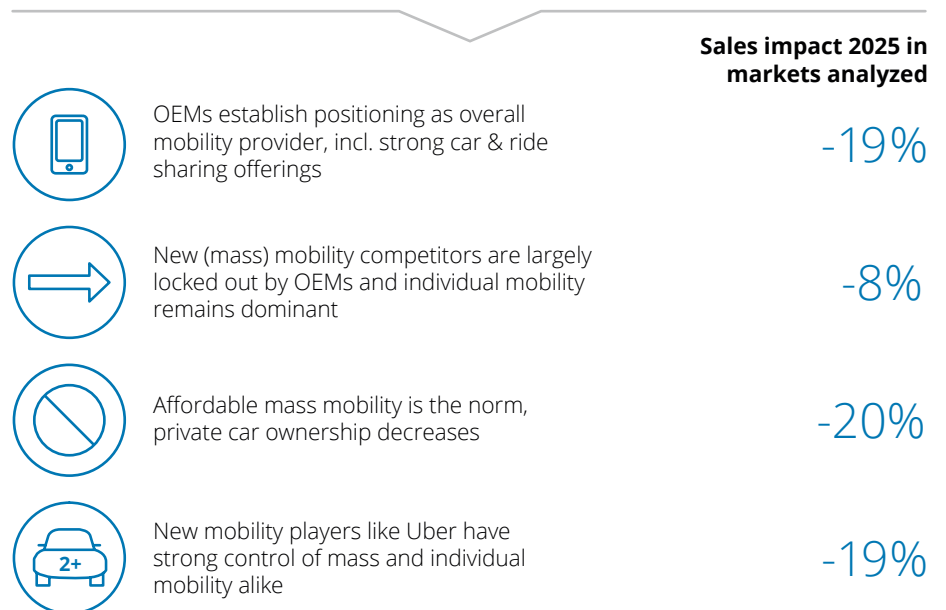
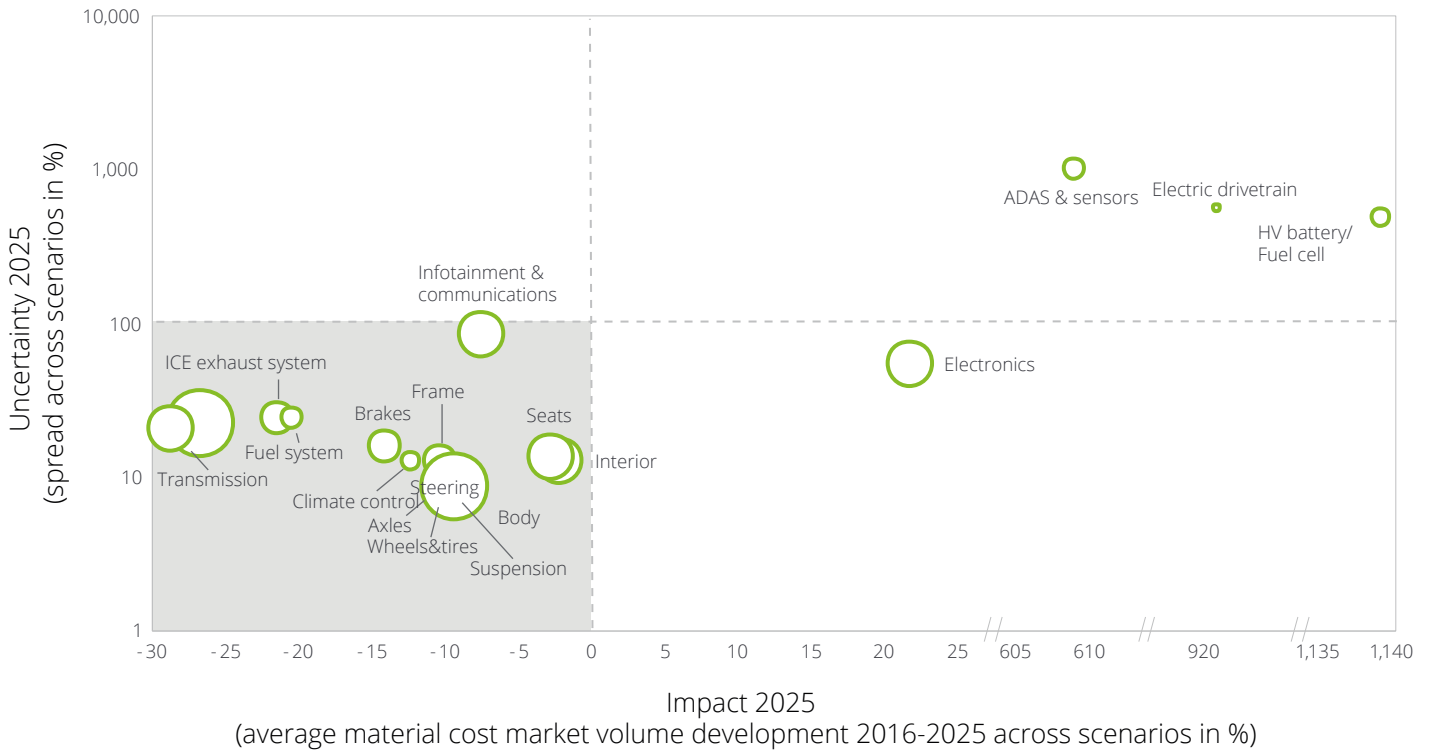

Fig. 10 – Impact versus uncertainty of material cost volume developments (2016–2025) across all scenarios²



□ Bubble sizes indicate the overall market volumes 2016 (Germany, NAFTA, China)

Overarching model results

Modeling four different scenarios for the automotive value chain in 2025 indicates that exponential developments are expected, especially in the areas of electric drivetrain technologies, advanced driver assistance systems as well as high voltage batteries. Stagnating or declining developments can be seen across scenarios and independent of the regional environment in the conventional component clusters, such as ICE, transmission, suspension, fuel and exhaust systems.

Model outcomes can best be summarized in an overview highlighting both impact and uncertainty of expected material cost volume shifts (figure 10). Uncertainty describes the average market volume spread within each vehicle component cluster across the four scenarios. Impact describes the average material cost volume development 2016–2025 across scenarios

(in %). Please note that all numbers exclude inflation effects within the given time frame. What stands out is that

- 15 out of 19 vehicle component clusters will likely see a decline in market volume (not considering effects from general inflation) across the entire scenario landscape.
- the winners will experience a noticeable impact on their business while most of the suppliers in the lower left quadrant will face high (displacement) competition and constant cost pressure. A fast strategy assessment and adaption to future needs are indispensable.
- vehicle component clusters related to the classic ICE vehicle, like transmission, combustion engine or fuel system, have to deal with the biggest challenges due to decreasing sales and smaller engines used in hybrid vehicles.

- vehicle modules related to electric drivetrain technologies and innovative areas like ADAS and sensors will see a further increase.

Regional differences are reflected in figure 11 (illustrative). While Germany's material cost volumes are facing a general decline until 2025 across the scenarios, Chinese material cost volumes will increase due to the generally strong development in vehicle sales.

Fig. 11 – Regional differences in an illustrative scenario

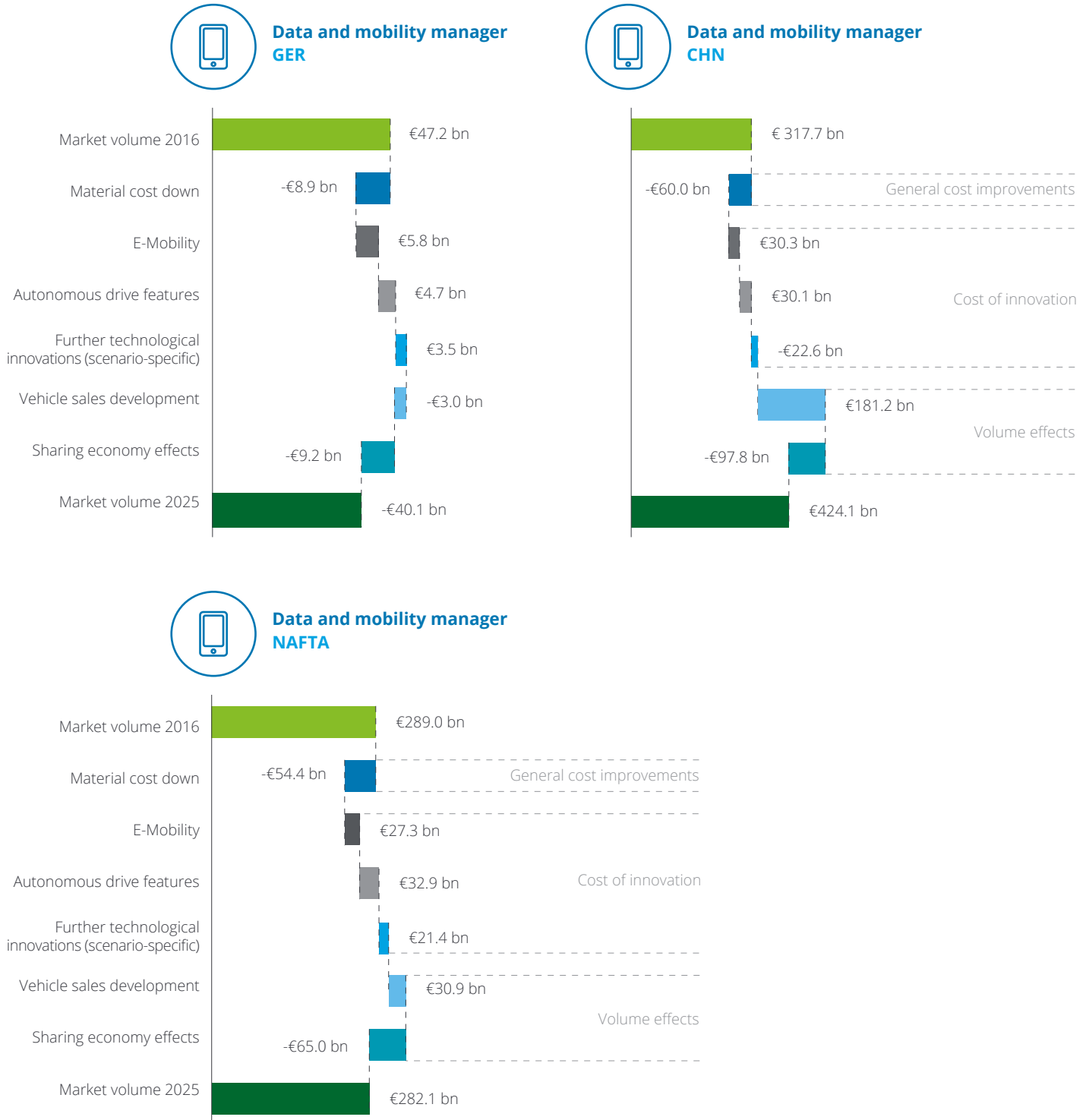

Taking another look at the global development across the four scenarios shows:

• **Data and mobility manager**

Due to the increasing importance of connected services and further successes in autonomous driving, ADAS & sensor technology and the market for electronics are on the winning side. High voltage batteries grow strongly because of increasing e-mobility market penetration. On the other hand, ICE-related clusters like the transmission or exhaust system and conventional hardware components lose market share. The ICE engine itself keeps a relatively high volume but is in strong decline.

• **Stagnant car maker**

High voltage batteries and fuel cells grow far less while the ICE cluster sees only a moderate decline. Autonomous driving is not a promising field for suppliers. Conventional automotive hardware parts face constant cost pressure. On average, growth developments are less strong than in other scenarios.

• **The fallen giant**

Due to the fact that affordable mass mobility dominates the markets, the negative vehicle sales effect from sharing economy is even stronger than in the other scenarios. Furthermore, the high market penetration of autonomous drive level 3 vehicles pushes demand for ADAS & sensors. By contrast, Infotainment & Communications decrease because the general technology hype cools down. ICE-related clusters decrease just slightly.

• **Hardware platform provider**

Autonomous driving plays a decisive role, thus the ADAS & sensors market as well as the market for electronics see a huge growth development. Tech players designing new automotive services and platforms demand innovative software solutions. ICE-related clusters like transmission face a decline due to an increasing number of alternative drivetrain vehicles. Consequently, the demand for high voltage batteries related to electric drivetrains grows rapidly and reaches a significant market volume in this scenario.

In 2025, changes in market structures and technology developments will likely lead to significant adjustments regarding product portfolios, business models, and organizational structures. Comparing all 19 clusters in several categories, we identified four deep dive topics (chapter IV) that are of particular interest.

The results from the Deloitte AVC Industry Model can be sliced by vehicle module and influence factor, making deep analysis possible and showing significant differences for each vehicle module and region. We continuously update and discuss our modelling assumptions, so the model can be customized and used for client-specific challenges.

Fig. 12 – Deloitte Industry Model: Available data splits

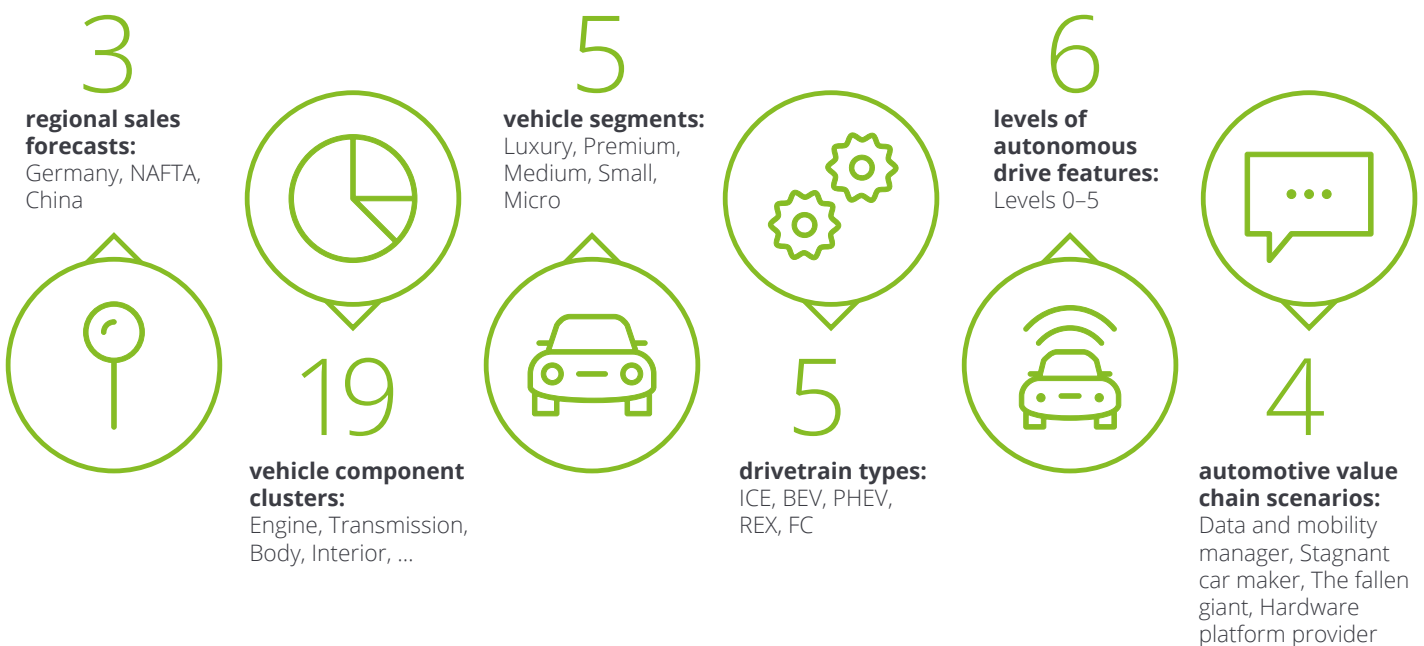
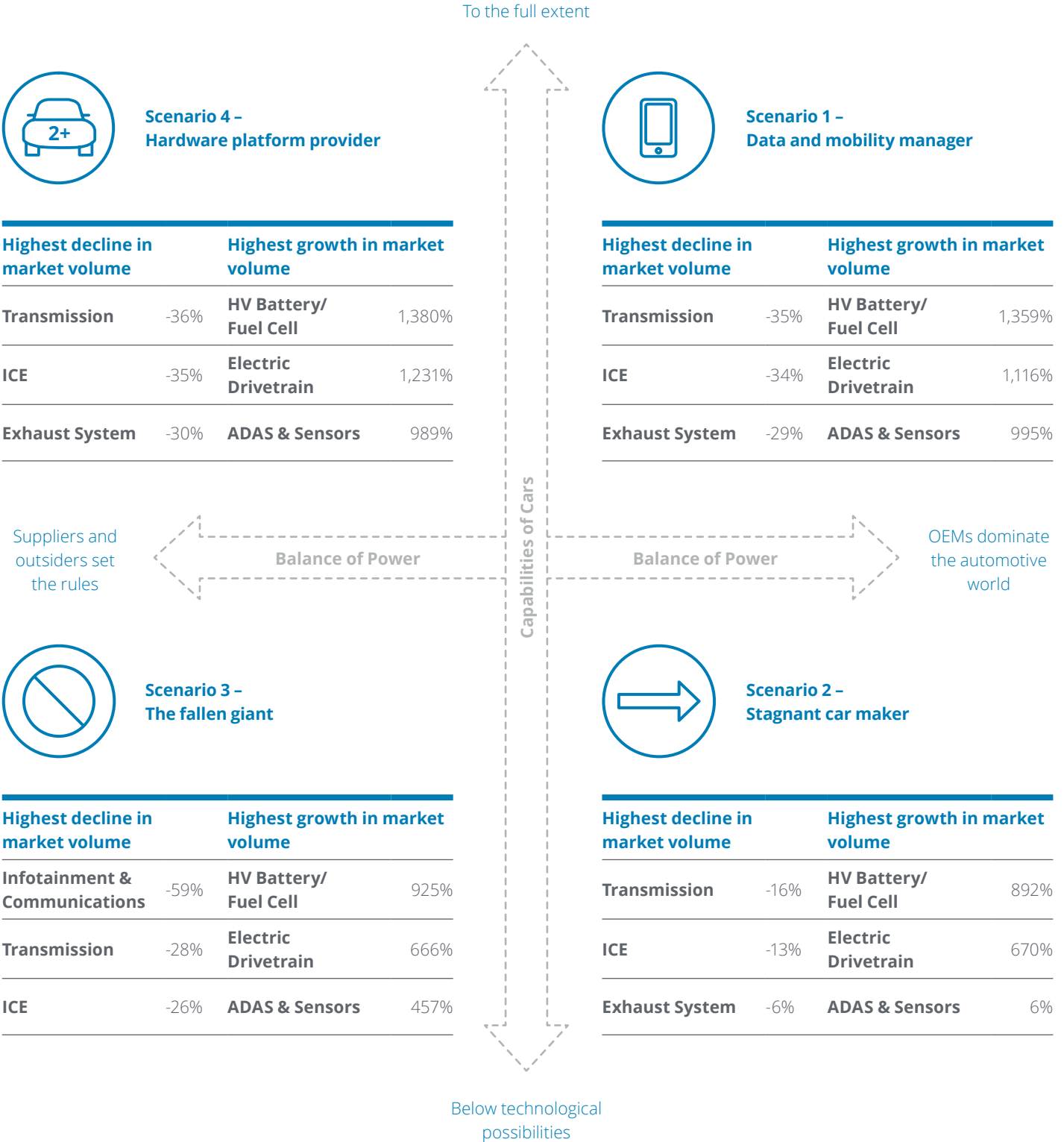

Fig. 13 – Winning and losing vehicle component clusters per scenario (Germany, NAFTA, China)



Investigating specific material cost developments: Selected model deep dives

In order to illustrate highly significant material cost developments towards 2025, this chapter will explore specific technology trends that fed into our modelling assumptions. As highlighted in figure 10, the most affected vehicle component clusters in terms of impact and uncertainty will likely be:

- **Interior & infotainment systems**
- **Drivetrain technologies (incl. ICE, transmission and alternative drivetrains)**
- **HV batteries & fuel cells**
- **Driver assistance systems**

The following illustrative deep dives demonstrate the capabilities of the Deloitte AVC Industry Model.



Deep Dive 1: Interior & infotainment systems

Among all vehicle component clusters, infotainment, communications & interior will probably be the ones with the strongest influence on the customer experience in the upcoming years and will therefore shape the view of customers on cars as a means of transport. If and when fully autonomous vehicles become the norm, passengers will not only want to arrive at their destination, but also want to be entertained during the ride. Levels of cost efficiency are improving rapidly, but they will not be able to compensate for additional costs due to higher customer demands.

All aspects of the human-machine interface in vehicles will gain importance in the upcoming years. For example, strong progress will likely be seen in the realization of head-up displays and touch technologies. This gives customers better usability of new in-vehicle services such as predictive maintenance or app usage. Rear seat displays can be equipped with interactive city maps, information about the surroundings (e.g. local sights), and other forms of entertainment.

However, the car of the future will not necessarily have more displays in total: Smart surface integration solutions allow, for example, for read-outs to be displayed on various surfaces like windows or armrests. LED lighting can be integrated directly on textile surfaces. All interior surfaces might have a second or a third purpose. Buttons, switches and knobs will be made increasingly redundant.

Customized intelligent seats detect stress levels and notify the driver accordingly, while biometric sensing systems monitor a passenger's health and well-being. Seating in general will gain higher attention in increasingly self-driving cars: Rotating seats are already a regular feature in future vehicle prototypes.

However, in our material cost forecasts we do not expect highly autonomous cars (levels 4 and above) to be the norm on the roads by 2025, so rotating seats will likely not have a strong overall volume impact by then.

Fig. 14 – Market volume forecast 2025: Infotainment & communications

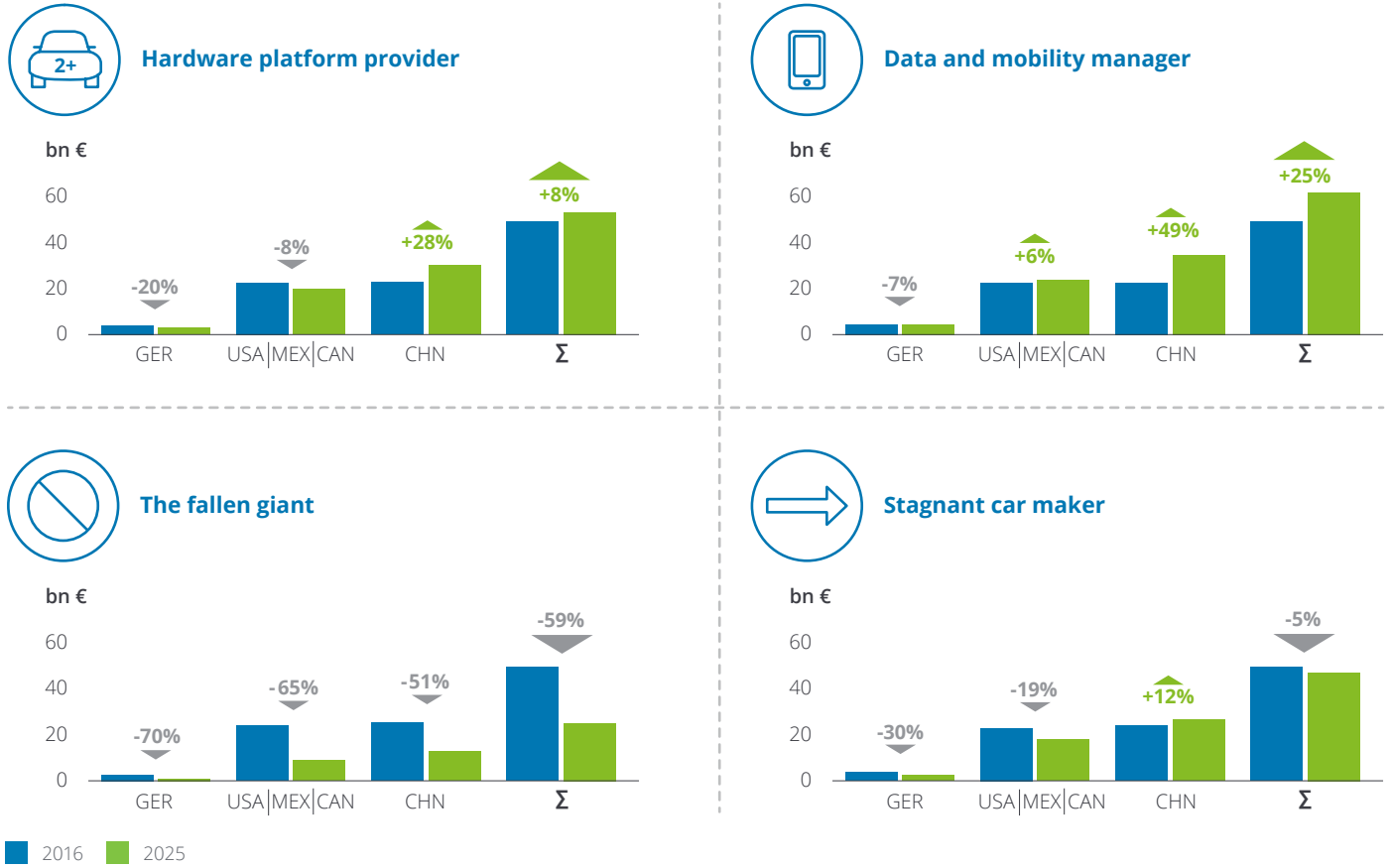

Depending on the scenario for 2025, vehicles will have plenty of connectivity features: Customers demand media technologies, making internet access a must-have for future passenger cars. This enables a wide spectrum of opportunities like 5G - based music streaming and access to social networks, just to name a few (already existing) examples. But on the other hand, connectivity leads to higher demands on electronic controller units (ECU) and sensors, causing cost increases for which customers are not necessarily willing to pay.

V2X communication is another cost driver, as it requires specific equipment such as additional wireless technology. Based e.g. on ITS G5, it enables various safety applications like forward collision or hazard warning.

All of these trends will likely lead to strongly increasing material cost levels in the vehicle of the future. One significant counter-effect – potentially lowering cost – might be the use of smartphone mirroring: Connecting a passenger's smartphone to the vehicle makes the phone's applications available for display in the car's head-unit. GPS systems or other comparable software and data services would, therefore, become obsolete and lead to material cost reductions.

For 2016, we calculate a total material cost volume (Germany, NAFTA and China) for these vehicle component clusters of €46.9 bn (Infotainment & Communications), respectively €122.9 bn (Interior, incl. seats and climate control). Due to a strong dependence on how technological possibilities are used and integrated in the vehicle of the future, total volume forecasts for 2025 show a wide spread over the four scenarios.

Fig. 15 – Market volume forecast 2025: Interior (incl. seats and climate control)

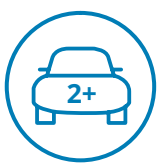
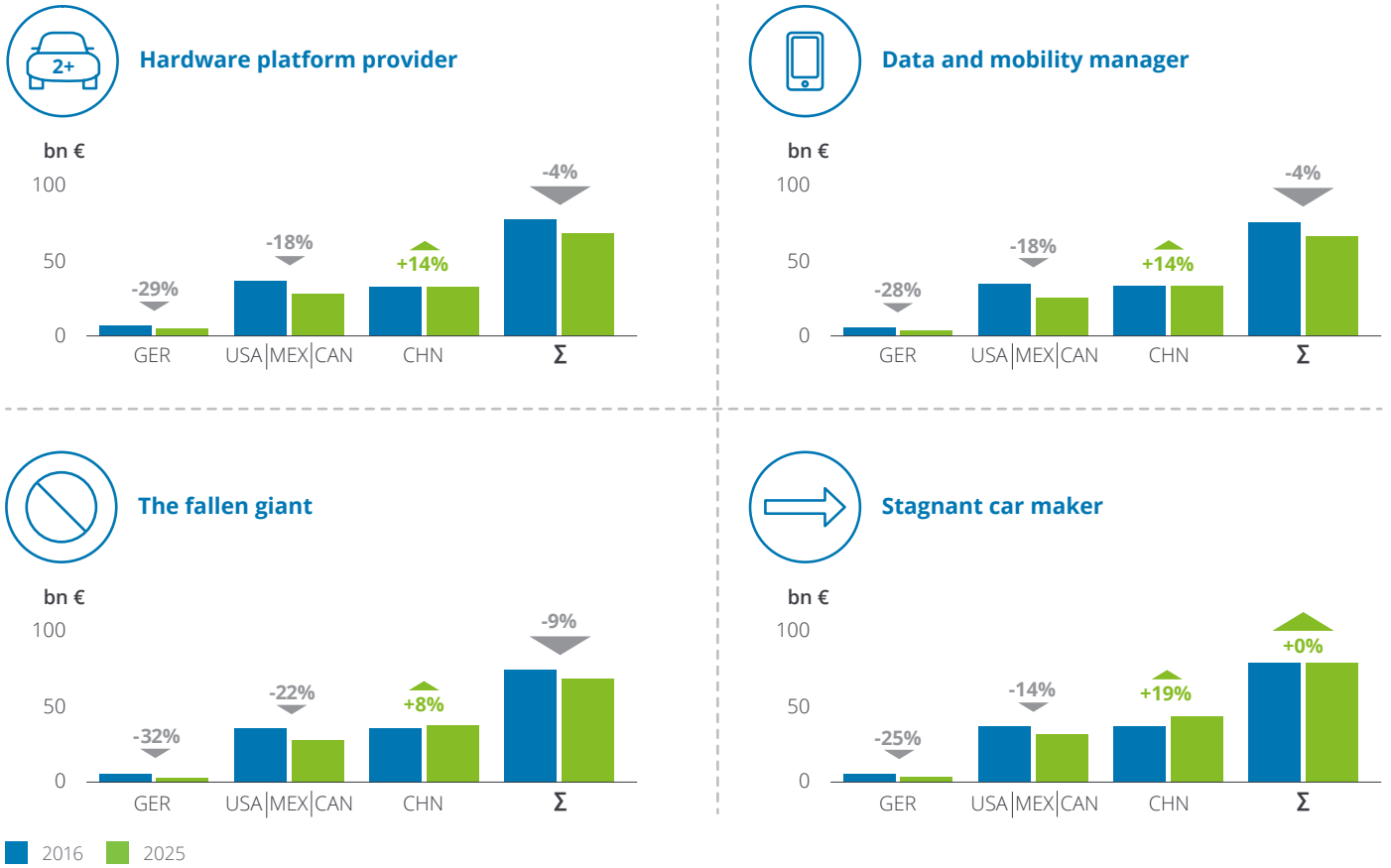

Hardware platform provider

We are in a world of fully connected cars which communicate with each other. Connectivity and all forms of digital innovations inside the car are highly in demand.

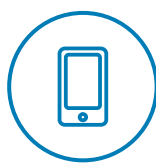

Data and mobility manager

Technological opportunities are utilized to the full extent. Infotainment & communications components integrated in the interior are a must for OEMs.

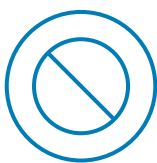

The fallen giant

A strong decrease of relative material cost of infotainment & communication and interior components is likely, as affordable mass mobility is most prevalent in this world.

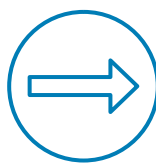

Stagnant car maker

The hype around connectivity technologies is gone, making it difficult for specialized suppliers to grow.



Deep Dive 2: Drivetrain technologies incl. ICE, transmission and alternative drivetrains

Almost all OEMs and many suppliers are putting immense effort into the research and development of alternative powertrains. The ICE manufacturing industry is affected by increasingly stricter environmental regulations. Gasoline engines can still be optimized through down-/up-sizing technologies. Diesel engine components such as injectors and high-pressure pumps can also be optimized incrementally. Additionally, there are ICEs that work with alternative fuels (ethanol, biodiesel, CNG, LPG). In general, however, investments in new ICE technologies are expensive and seem highly risky in the long view (see Figure 16 for Deloitte's projections on the development of alternative drivetrains). Recent announcements from Britain, France (2040), India (2030), and Norway (2025) on dates for planned ICE sales bans add further validation to these notions.

However, a complete end to all ICE sales is not likely either, and there might also be business potential for selected providers in a strongly consolidated market.

Together with alternative drivetrain concepts, transmission components have to adapt. Overall, the demand for transmissions due to alternative drivetrains is decreasing due to smaller sized transmissions or even no need for transmissions at all. A remaining cost driver could be hybrid transmissions with integrated electric motors, complex mechanical design and additional parts, e.g. power connections. Also, dual clutch transmissions (DCT), which have seen high market growth in the past years, might see relatively stable volumes in the foreseeable future. Continuously variable transmissions (CVT) make some components obsolete (fewer gears, cogs,

and moving parts) and reduce complexity. In any case, OEMs will try to decrease overall cost levels as much as possible in this component cluster.

Currently, material costs for electric drivetrains are relatively high. This will change over time. For example:

Fig. 16 – Deloitte E-Mobility Model – Development of alternative drivetrains

Annual sales of alternative drivetrains in million car sales and share of total vehicle sales (model incorporates data from China, NAFTA, and Germany)

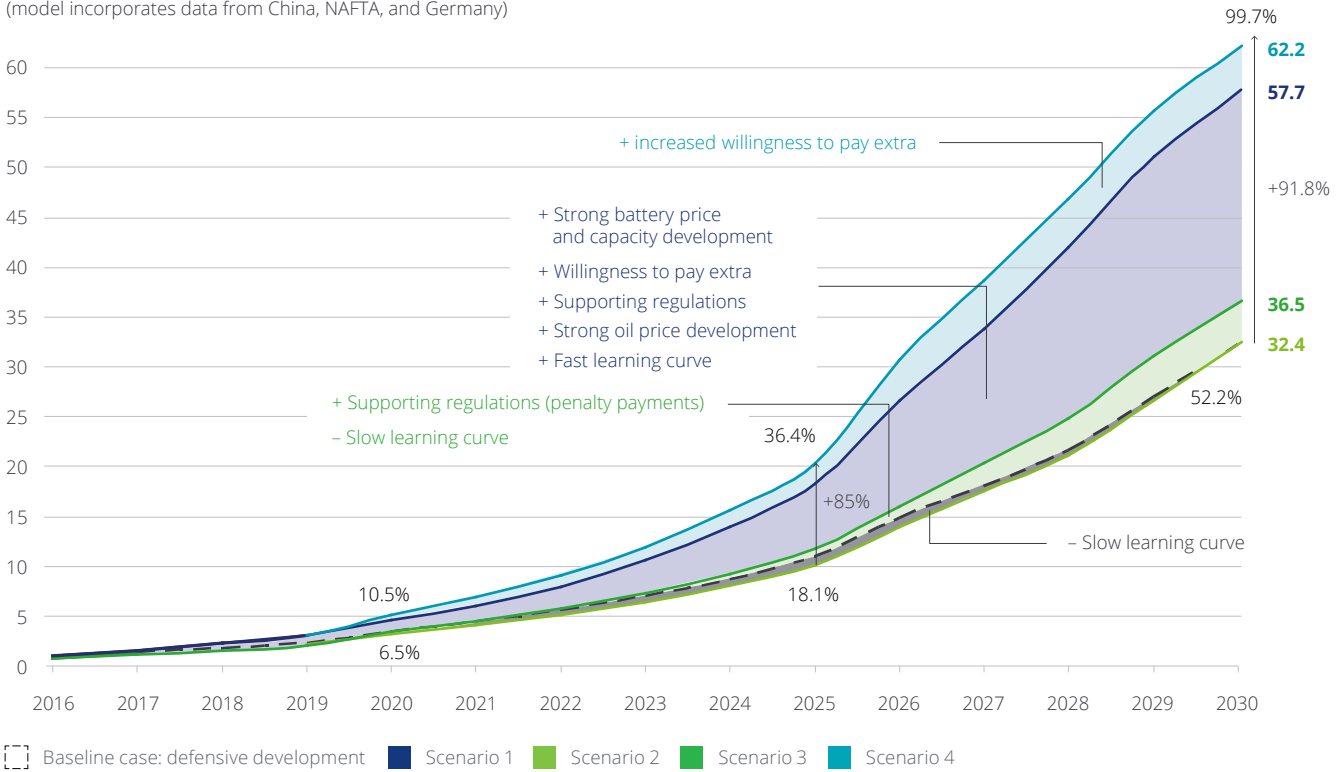

Increasing electrification will not only lower demand for internal combustion engines, but also for transmissions

- Electric engines without rare earth elements (e.g. induction engines) can reduce production costs by 20–30% in upcoming years.
- Costs can be reduced by making engines smaller and lighter. This can be achieved by, e.g., using silicon carbide transistors for the engine electronics to reduce the size of capacitors.
- Depending on the general market demand for alternative drivetrains, we foresee a strong market volume increase across all scenarios. All electronic-related parts like power electronics, converters/inverters and electric motors face much higher demand.

The total material cost volumes in 2016 were €107.1 bn (ICE) and €1.3 bn (Electric Drivetrain). Depending on the scenario we expect the following market volume trends:

Fig. 17 – Market volume forecast 2025: ICE

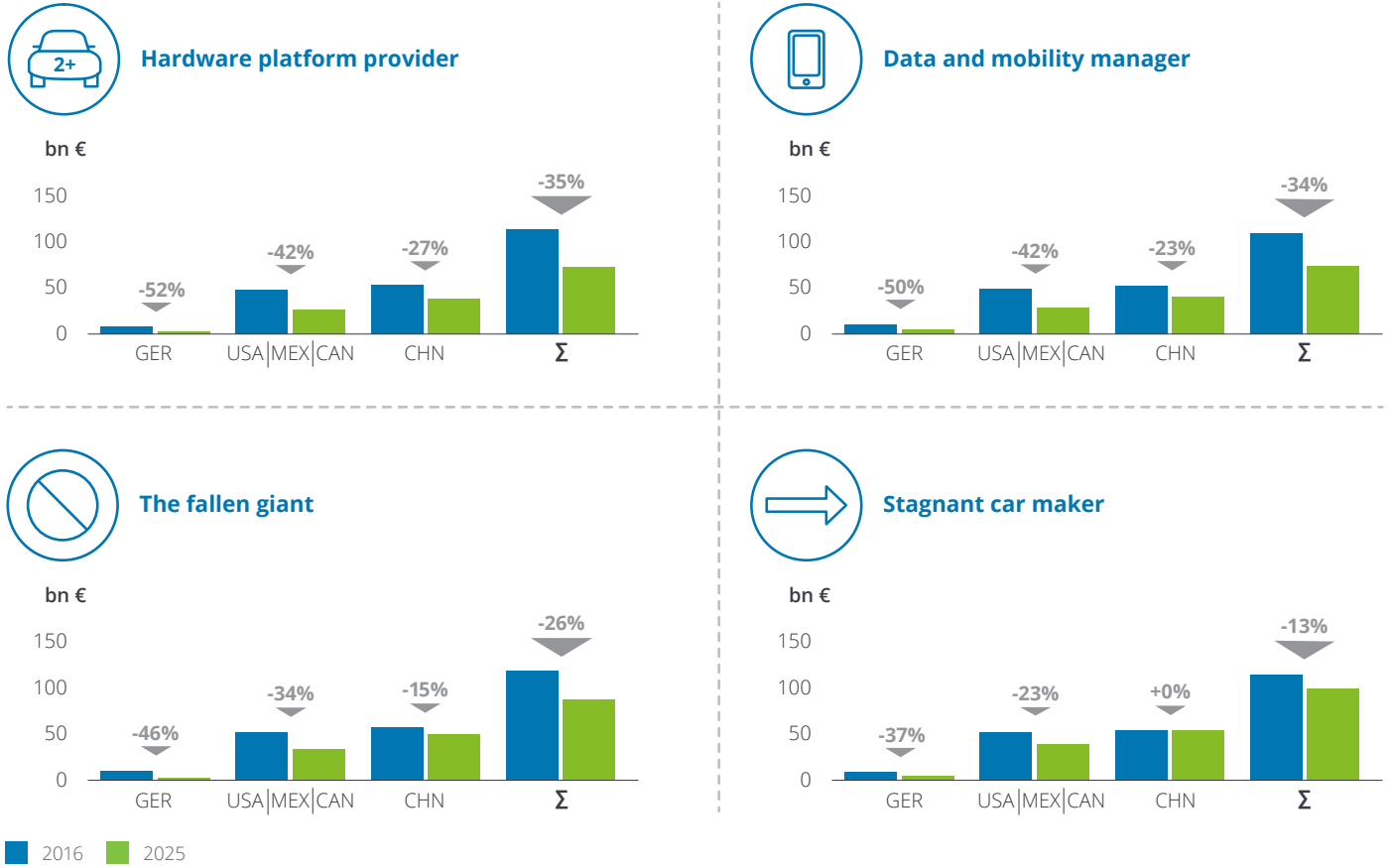

Investments in new ICE technologies are highly risky in the long view – across all four scenarios

Fig. 18 – Market volume forecast 2025: Electric Drivetrain

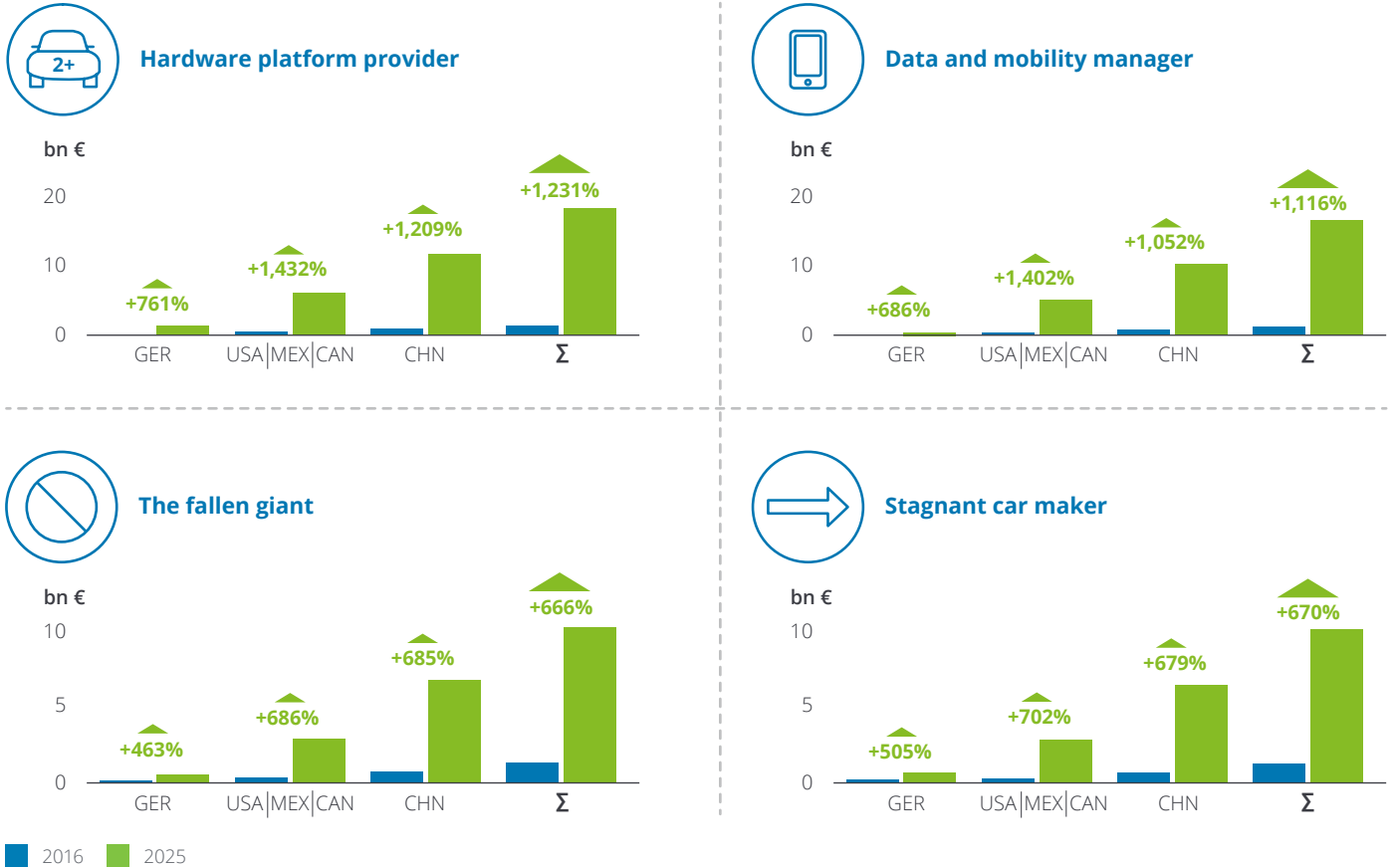

Hardware platform provider

IT players foster the electric drive technology. This yields new chances for non-conventional automotive suppliers. ICE engine suppliers face drastically shrinking volumes.

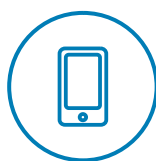

Data and mobility manager

Alternative drives are definitely in focus, the demand for electric motors and power electronics increases strongly, whereas demand for ICE shrinks.

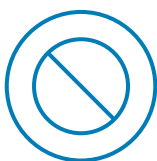

The fallen giant

Regulators reinforce the shift towards e-mobility. Public e-mobility offerings only have limited customer acceptance and market success.

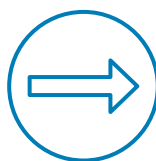

Stagnant car maker

Combustion engines and alternative drivetrains coexist, e-mobility emerges as an independent business model.

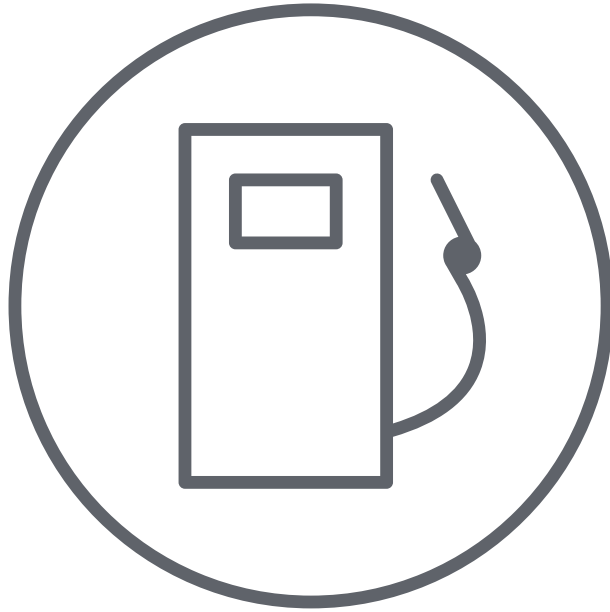

Deep Dive 3: HV batteries & fuel cells

The main issues in the way of mainstream market adoption of alternative drivetrains are charging times, cost, and range. All of these problems come down to energy storage: The battery or fuel cell component.

Battery packs represent around 25–40% of the value of fully electric vehicles. It is needless to say that the price development of batteries remains crucial to the market acceptance of electric vehicles. The most promising innovations for the automotive manufacturing industry are currently based on lithium-ion batteries (LiBs). For PHEVs and BEVs, higher energy densities and higher power capable electrode materials like lithium-ion are needed. Battery aggregates for electric vehicles can be broken down to the battery cells, modules, and whole packs. LiBs can improve overall costs due to a lower number of cells needed for an entire battery pack.

Because HEVs require lower energy capacities than BEVs, preferred batteries for HEVs are not only LiBs, but also nickel-metal hydride (NiMH) batteries. In any case, LiBs are a good option on a price basis, given the large amount of lithium that is available. As the technology is relatively new, they are still expensive, but cost decreases coming from economies of scale and typical learning curves are expected.

Further battery types of the future are for example lithium sulfur and lithium air, which both promise higher energy densities than lithium-ions. But both technologies are still in early development and not expected to enter the market before 2025. Thus, at the moment everything comes down to the LiB market, which is currently dominated by Asian companies, in particular from Japan and South Korea.

Due to an expected progressive market penetration of BEVs and PHEVs, we will see a strong increase in demand for LiBs in future years. As battery manufacturers try to anticipate this progress, they have built up battery capacities in advance over recent years. Thus, battery manufacturing plants currently face low utilization rates of around 65% of production capacities. It remains to

Fig. 19 – Deloitte E-Mobility Model – Battery price development

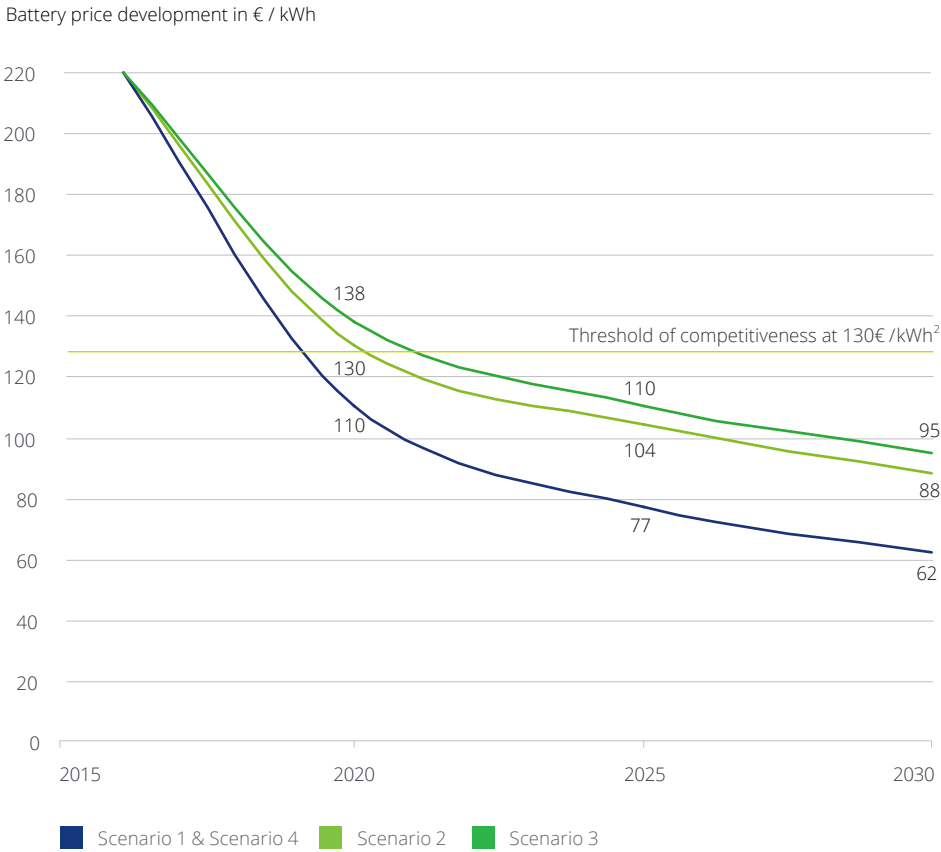

be seen whether the demand for batteries will grow fast enough to change this, as important market players have already announced that they intend to establish further battery capacities. Excess capacity, however, typically leads to decreasing market prices.

In recent years, the battery price in €/kWh has strongly decreased. Starting at €900/kWh in 2010, we are now at just over €220/kWh, and further cost decreases are expected. From our research, a price level of €130/kWh is seen as necessary to establish battery EVs on a broad basis (figure 19).

The future differentiator in the battery market is considered to be neither the size or range of electric vehicles, but in their charging time. In that field, flash batteries can play an important part, as they can drop the charging time down to just five minutes. Since this technology is also still in the early stages of its development, the use of flash batteries in vehicles would come only with significant material cost increases.

All those challenges are not apparent in fuel cell electric vehicles (FCEV). They can be fueled just as fast as conventional ICES and their ranges are comparable. Even though FCEVs are relatively expensive, they become cheaper by reducing the amount

of platinum which is used for the platinum catalyst that splits the hydrogen. But the main issue for FCEVs is that there are only very few hydrogen fueling stations, far fewer than public electric charging stations, as these are extremely expensive and demand is not overly apparent.

In total, we estimate the material costs volume for HV Batteries and Fuel Cells in 2016 at around €5.5 bn in the markets analyzed. The battery market volume will see a high increase across all scenarios. Nevertheless, the volume development until 2025 highly depends on the speed of the e-mobility uptake per scenario:

Fig. 20 – Market volume forecast 2025: HV batteries / fuel cells



Hardware platform provider

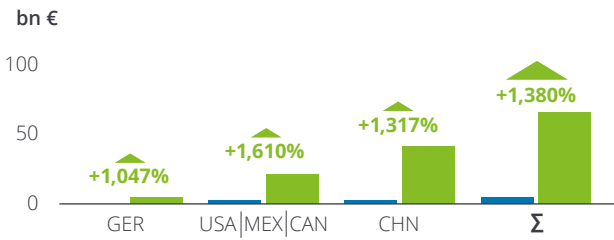

Data and mobility manager

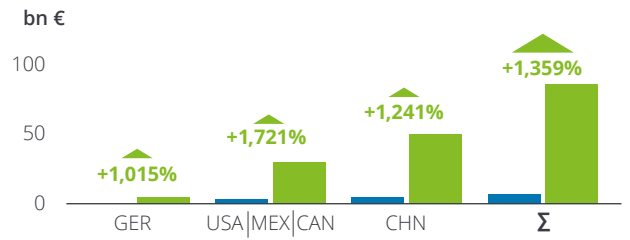

The fallen giant

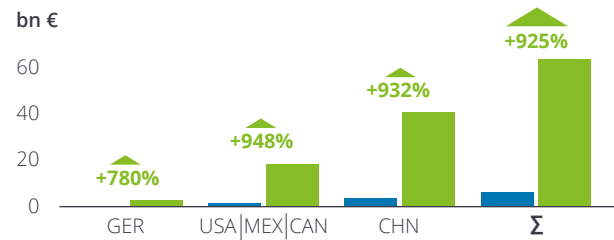

Stagnant car maker

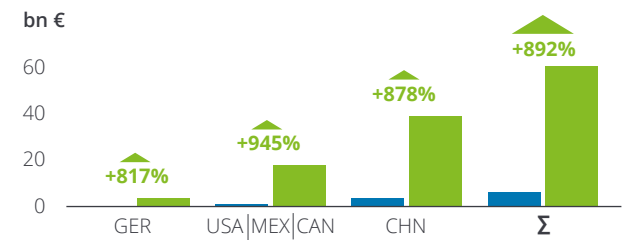

■ 2016 ■ 2025



Hardware platform provider

IT players are driving the trend towards electric vehicles. The supply of (components for) batteries creates new opportunities for non-conventional suppliers.



Data and mobility manager

As e-mobility is in focus, optimized batteries and innovative charging solutions for these are in high demand.



The fallen giant

Even though the government tries to push the shift towards e-mobility, consumers only use it to a limited extent. R&D investments in battery innovations have cooled down.

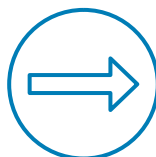

Stagnant car maker

Electric drivetrains co-exist with ICEs, thus efficiency improvements in batteries are crucial for the competitiveness of electric vehicles.



Deep Dive 4: Driver assistance systems

Autonomous drive technology has the potential to completely transform mobility industries. In each step towards a fully autonomous vehicle, different development and complexity stages of Advanced Driver Assistance Systems (ADAS) are used to set the technical foundation. Various sensors around the car detect obstacles, help keep the vehicle on track and warn the driver in case of danger. ADAS applications not only ensure a higher safety level for the driver by providing the vehicle with more information about its surroundings, but also promote comfort. The different stages of autonomous driving can be differentiated in levels from 0 to 5 (figure 22).

In a Level 5 vehicle no human intervention is required, other than setting the destination and starting the system. In order to get there, OEMs, suppliers, software companies, regulators and other stakeholders have to solve a number of potentially show-stopping issues, ranging from the development of reliable driving functionalities to settling remaining legal concerns (figure 22).

Fig. 21 – Industry challenges until series maturity of autonomous vehicles





Key development topics	Description
 Function/Software	Human cognitive abilities must be reproduced
 Back end/ HD Map	Highly accurate maps and localization are a prerequisite
 Fail-Operational Architecture	New architectures needed to control car in "first failure" cases until driver takes over (about 5–10 seconds)
 Method Assurance	New hedging methods are required
 Legal Aspects	Change of existing laws and regulations. Cars, not humans, will make maneuver decisions.

Fig. 22 – Levels of autonomous drive



Source: Deloitte Consulting

OEMs, suppliers, software companies, and regulators still have to solve a number of potentially show-stopping questions to establish fully autonomous vehicles

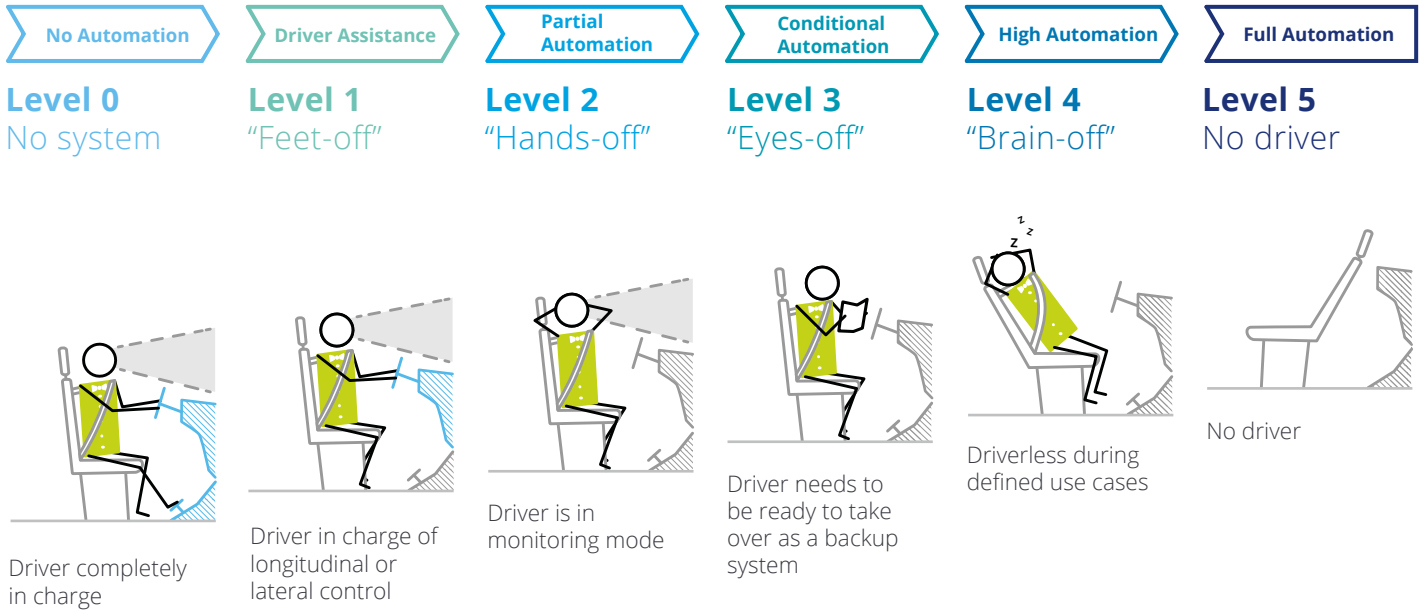
Rough estimations suggest that a vehicle upgrade to Autonomous Level 5 might come at a cost of several thousand euros per vehicle from today's perspective and an end-customer's point of view. Although the costs of hardware and software components will decrease over time, we assume that the strong increase in required components and higher degree of system integration complexity will keep overall costs high. As ADAS applications stand for more safety, governments or organizations like the European Union might push all vehicle manufacturers to provide more of such applications over time, increasing the demand drastically.

The sensors themselves will likely become smaller and functionally more capable. An increasing number of radar and lidar sensors and cameras, which are necessary for any adaptive cruise control system, will be integrated in more and more vehicles.

In order to improve ADAS, constantly increasing processing power is required due to more complex sensor fusion. Higher performing electronic controller units (ECU) and microcontroller units (MCU) will drive costs. The need for processors with higher performance results in the development of smart sensors which come with integrated processors. Hardware costs itself could decrease due to increasing production technology capabilities.

Apart from the hardware components, ADAS needs smart software algorithms which always take correct action to guarantee safety for the passengers. Software platforms running on centralized ECUs or MCUs are used to make sensor fusion easier.

All of these factors will likely drive up vehicle costs significantly. Considering the high uncertainty of future technological solutions in the field of autonomous driving, we modelled four material cost projections.

Fig. 23 – Market volume forecast 2025: ADAS & sensors

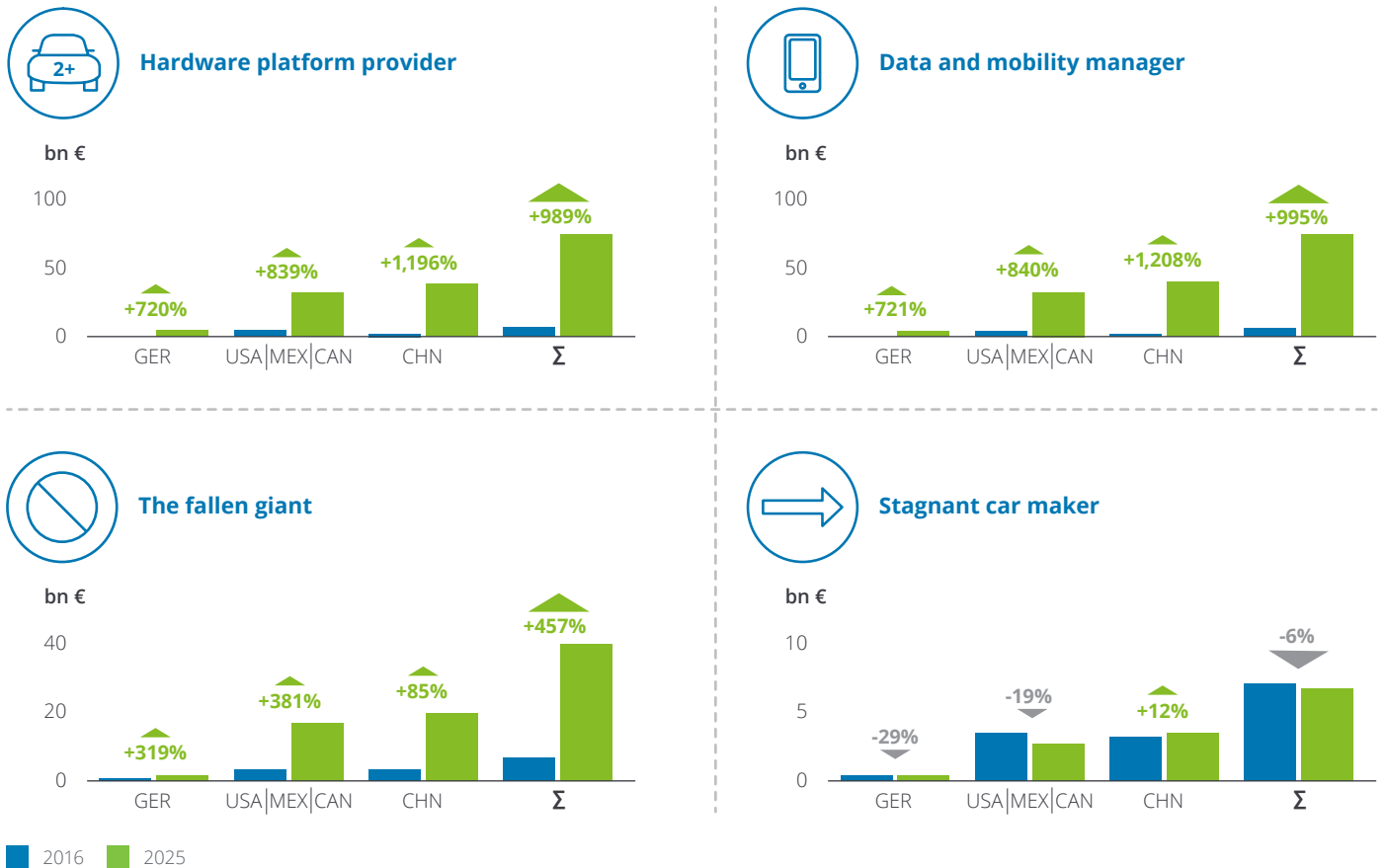



Hardware platform provider

Autonomous driving features are highly in demand by both OEMs and new mobility players: AD level 3 (driver must be ready to take over as a backup) is assumed on average across the markets and vehicle segments analyzed.

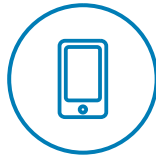

Data and mobility manager

Massive increase of integrated ADAS: AD level 3 (driver must be ready to take over as a backup) is assumed on average across the markets and vehicle segments analyzed.

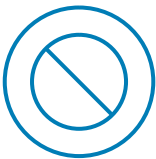

The fallen giant

Autonomous drive technology in large mass mobility fleets has become part of life: AD level 2 (driver is in monitoring mode) is assumed on average across the markets and vehicle segments analyzed.

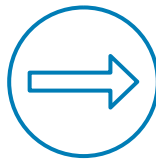

Stagnant car maker

Autonomous drive is not widely accepted: AD level 1 (driver in charge of longitudinal or lateral control) is assumed on average across the markets and vehicle segments analyzed.

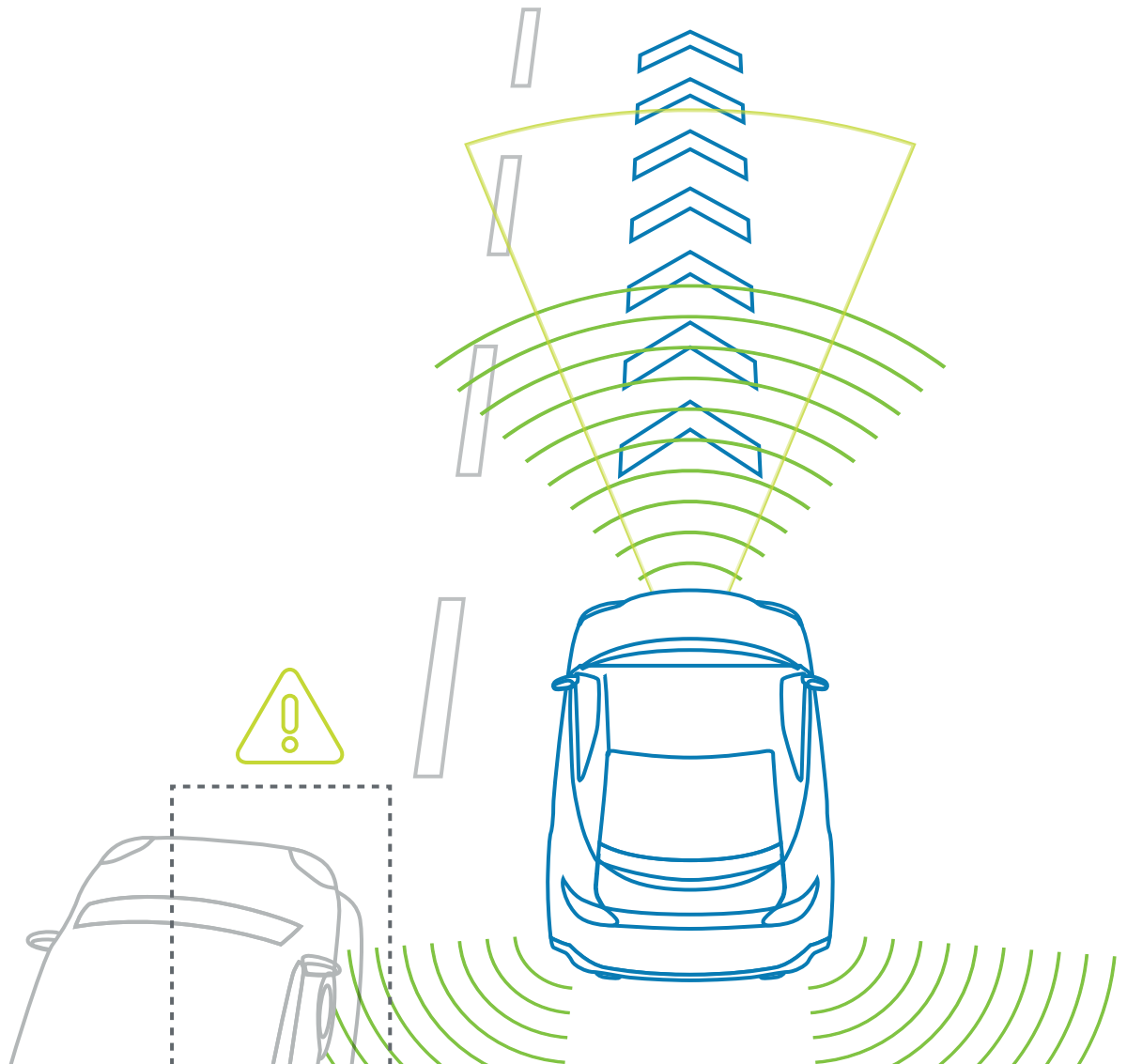

Overall model result overview

Fig. 24 – Deloitte AVC Industry Model: Result overview of scenario-specific material cost volume developments³ for Germany, NAFTA and China towards 2025

Vehicle component cluster (GER, NAFTA, CHN)	Total Volume 2016 in € bn	Volume Development 2016–2025 S1	Volume Development 2016–2025 S2	Volume Development 2016–2025 S3	Volume Development 2016–2025 S4	Average Develop. 2016–2025 in %	Average Volume 2025 in € bn
HV Battery/Fuel Cell	5.5	+1,359%	+892%	+925%	+1,380%	+1,139%	68.1
Electric Drivetrain	1.3	+1,116%	+670%	+666%	+1,231%	+921%	13.2
ADAS & Sensors	6.4	+995%	-6%	+458%	+989%	+609%	45.4
Electronics	50.3	+48%	+6%	-6%	+40%	+22%	61.2
Interior	71.5	-2%	+1%	-8%	-3%	-3%	69.3
Seats	39.3	-3%	+1%	-9%	-3%	-4%	37.9
Infotainment & Communications	46.9	+25%	-5%	-59%	8%	-8%	43.3
Body	114.9	-11%	-4%	-12%	-11%	-9%	104.2
Suspension	12.0	-11%	-4%	-13%	-11%	-10%	10.8
Steering	15.0	-11%	-4%	-13%	-11%	-10%	13.5
Wheels & Tires	22.2	-12%	-4%	-13%	-12%	-10%	19.9
Frame	22.3	-11%	-4%	-16%	-11%	-10%	19.9
Axles	20.7	-12%	-5%	-13%	-12%	-10%	18.5
Climate Control	12.1	-17%	-5%	-14%	-17%	-13%	10.5
Brakes	16.3	-20%	-4%	-13%	-20%	-14%	14.0
Fuel System	7.1	-28%	-5%	-19%	-29%	-20%	5.7
Exhaust System	21.8	-29%	-6%	-20%	-30%	-21%	17.1
ICE	107.1	-34%	-13%	-26%	-35%	-27%	78.5
Transmission	61.3	-35%	-16%	-28%	-36%	-29%	43.7

■ Likely winners (volume increases in more than one scenario)
 ■ Uncertain component clusters (volume increases in one scenario)
 ■ Likely losers

What about software and digital services?

The results summarized above represent material cost developments along a conventional, i.e. hardware-focused, vehicle breakdown. As pointed out above, however, we expect a (scenario-specific) strong increase of OEM money spent on software and digital (data-based) services for the future. This is partly reflected in our modeling: Material costs for components sourced as embedded systems

include the additional value-add from the suppliers' software and service development. Most notably, this is the case for component clusters such as infotainment systems and driver assistance systems. An aspect not fully reflected in our overall modeling is purchasing volumes originating from vehicle-related software engineering (e.g. autonomous driving features) and new digital service offerings (e.g. connected infotainment, messaging, or vehicle health features). These volumes rep-

resent an additional upside to our material cost forecasts, as we consider current cost predictions not reliable enough at this point in time.

Nevertheless, developing, sourcing, and assuring quality of automotive software is an increasingly important topic. We further elaborate challenges and solutions in this field in our publication "Automotive Software Quality"⁴.

³Excluding inflation and spare part business

⁴<https://www2.deloitte.com/content/dam/Deloitte/de/Documents/risk/Risk-Risk-Advisory-Automotive-Software-Quality-DE-s.pdf>

Transformation paths towards 2025 for the automotive supplier industry

The results from the Deloitte AVC Industry Model shed light on substantial, in some cases even burning, needs for change. Modelling results trigger and support discussions about re-prioritizing product portfolios and market exposure. We believe that six strategic fields of action should be assessed by automotive suppliers when considering potential transformation initiatives towards 2025.

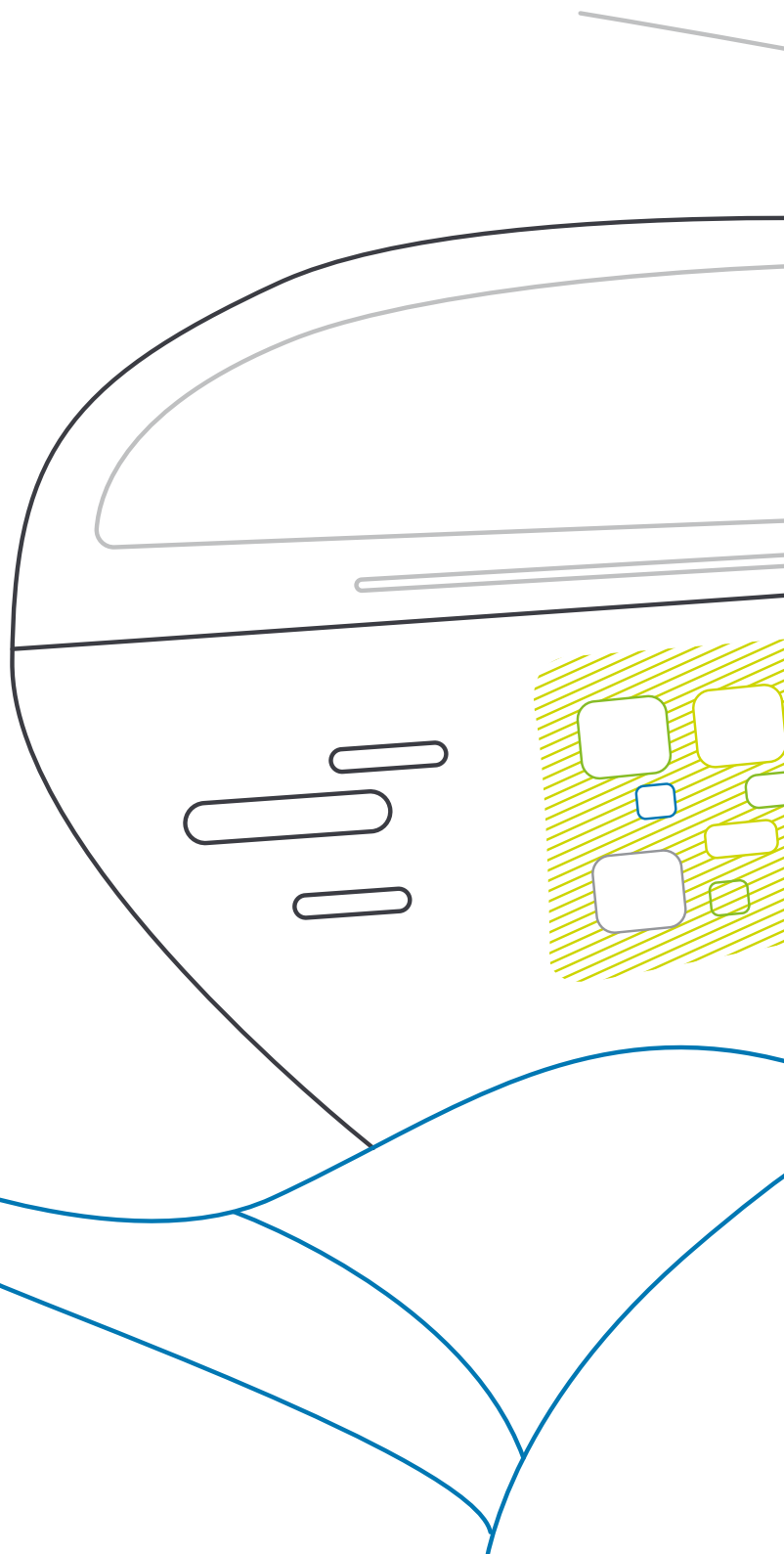

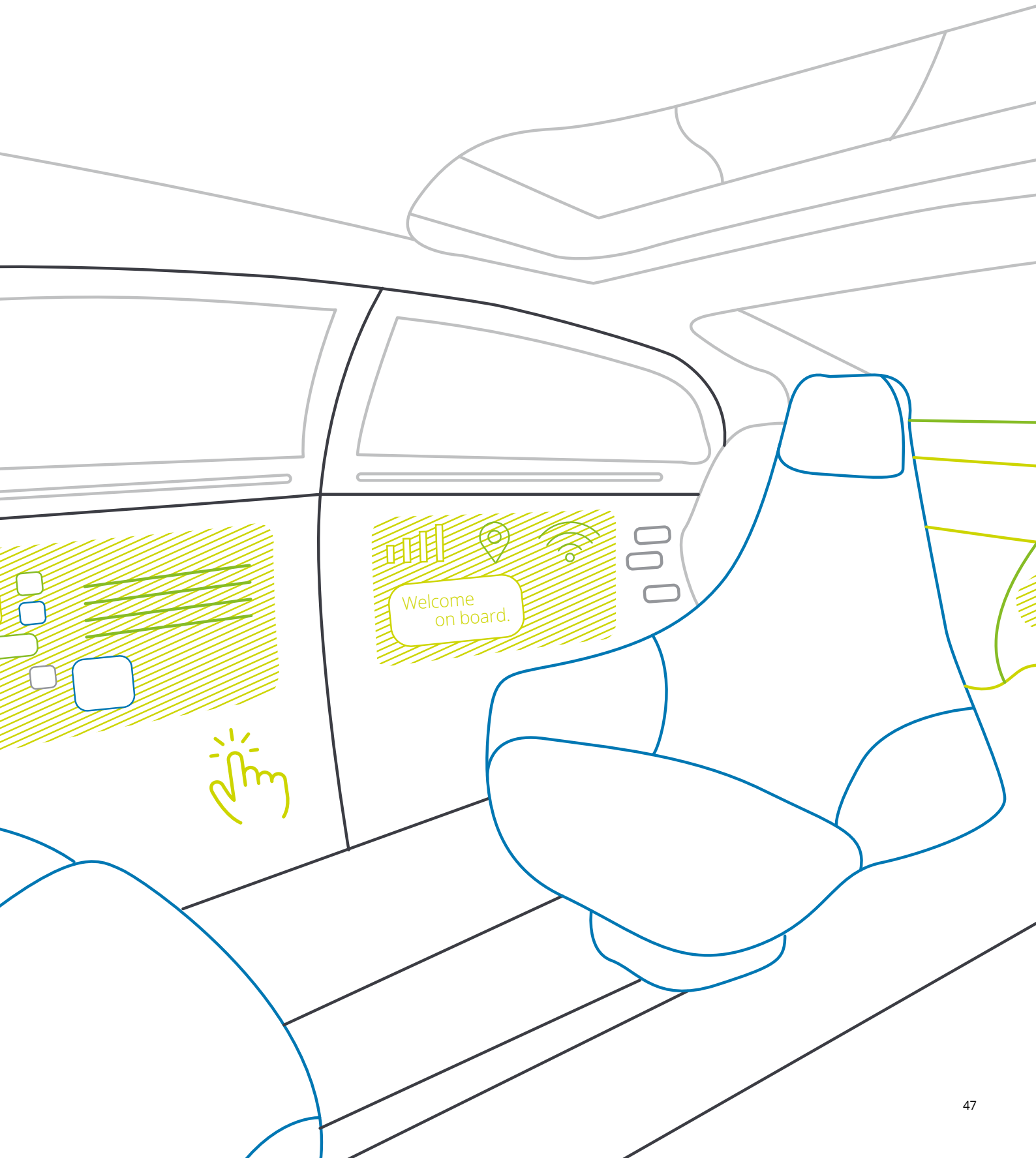

When analyzing scenario-specific material cost market developments along vehicle component clusters and regions, three key questions can help structure strategic considerations for suppliers:

- Do we expect sufficient growth and profitability in our current product portfolio and regional market footprint?
- Do modelling results rather suggest reviewing our product and service portfolio, as our current portfolio will become obsolete in parts or highly commoditized in the automotive future?
- Is it necessary to examine the regional customer focus and in turn reassess the current manufacturing footprint?

Naturally, answers will depend on the supplier's current setup along products and markets as well as the (scenario-specific) market development projections from the Deloitte AVC Industry Model. We believe, however, that six priorities should be at the core of every supplier's strategic planning towards 2025 and beyond.

The following chapters will illustrate transformation paths from the perspective of top decision-makers at a supplier for transmissions, which will likely face strong volume losses, as our projections in chapter III and IV showed.

Fig. 25 – Key transformation questions

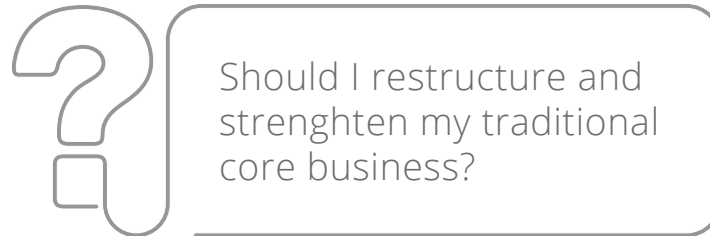

Volume projections trigger discussions regarding re-prioritizing both product portfolios and market exposure

Fig. 26 – Signature priorities for value chain transformations in automotive suppliers



Product portfolio shifts

As pointed out in the previous chapters, suppliers in most vehicle component clusters must cope with ongoing cost pressure combined with the threat of technological substitution of their current products. For suppliers most affected by these technological shifts, e.g. in the fields of ICE or transmissions, a radical shift in product offerings can be a life-saving move. But developing new product offerings and profit pools requires significant investments, which need to be financed from cash flows coming from the current core business (figure 27). In other words: Maintaining profitability despite shrinking volumes in traditional products and managing a quick innovation and ramp-up process of new products must go hand in hand. Results from the Deloitte AVC Industry Model can help to support financial planning in the light of this, which the following case study will illustrate. We simulated profit and loss developments for a generic supplier of transmissions, who is threatened by significant volume loss by 2025. The supplier's plan is to develop a second product segment: Electric drivetrains (figure 28).

The simulation is based on the first scenario "Data and mobility manager" and assumes a decrease in market demand of 19% for the supplier's transmission business as a mixed product portfolio of automatic and manual transmissions by 2025. Due to increasing cost pressure from OEM customers, prices are assumed to also shrink by 20% over time (inflation-adjusted). The supplier will not be able to compensate such a drastic price decrease with variable product cost reduction measures. Product margin loss of more than a quarter of the 2016 figure is the inevitable consequence. To make up for this, efforts for innovating the transmission product portfolio are almost fully ramped down until 2025.

On the other side, specific AVC Industry Model outputs imply a growing market demand for electric drivetrains by about sixteen times in relation to today. Learning effects and overall technology leaps will beat down prices by 30% over time, but also allow for variable cost reductions by almost 50% during the entire ramp-up period. Significant investments in new development stages of the electric drivetrain technology are needed. In summary, a consolidated view shows that the old technology manages to sponsor the ramp-up of a new technology in order to establish a new profit pool (figure 29).

Fig. 27 – Profit & loss simulation of portfolio shift for generic supplier



Source: Deloitte AVC Industry Model, Deloitte analysis

Suppliers must be capable of bridging years of negative returns from new technologies, subsidized by traditional profit pools

Fig. 28 – Profit & loss simulation of portfolio shift for generic supplier – consolidated profit view

In-house development

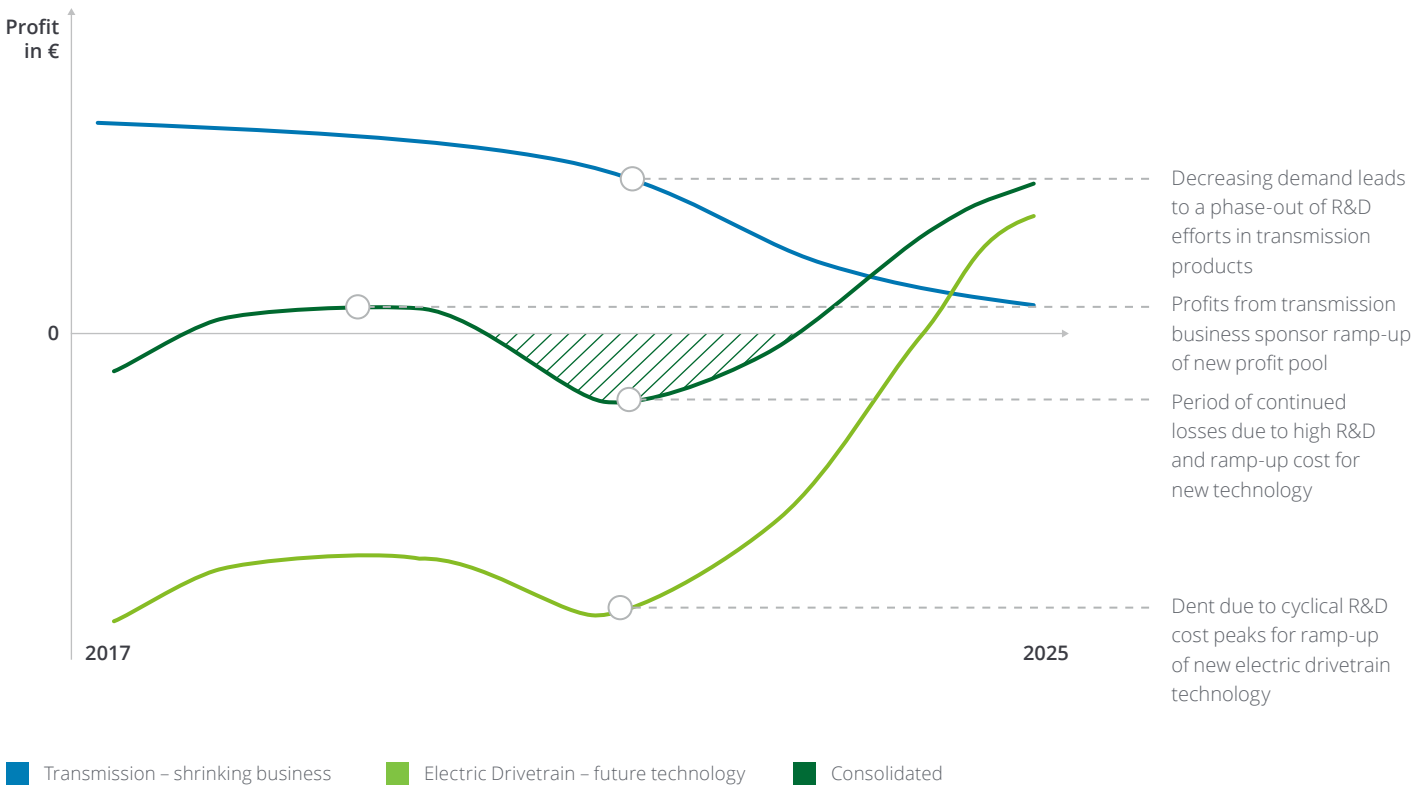

Source: Deloitte AVC Industry Model, Deloitte analysis

This example highlights the need to be able to bridge and sponsor up to seven years of negative profits from new technology and product innovation by the existing business. The dent in the consolidated curve is based on cyclical R&D cost peaks and ramp-up cost for future technology and development stages. Large financial efforts are required for this, so decision-makers and their shareholders must be prepared

to go through periods of strongly diminished or even negative profits. Many suppliers are and will be faced with such large scale transformation, which – as the simulation highlights – not only requires immense efforts from management and employees, but also careful deliberation of financial risk taking and margin expectations from shareholders. The next chapter shows one effective strategic approach to countering these negative effects.

Collaboration and platform strategies

The previous chapter focused on where to set priorities in developing product portfolios in accordance with automotive material cost projections. This chapter discusses how to develop and invest in new profit pools in a smart and collaborative way.

The simulation of the generic transmission supplier has shown that there might be phases of negative consolidated profits to endure during the reshuffle of the core business. Several examples in recent years have shown that collaboration and development partnerships in the automotive ecosystem are considered a viable strategy for decreasing development costs and reducing financial risk from failed investments. Depending on the specific scenario of a 2025 automotive world, it can be a lifesaving step to break today's strong dependency on OEMs and form new partnerships for joint innovation or high volume manufacturing orders (e.g. with new mobility players). Joint drivetrain developments by BOSCH and Schwalbe (for motorcycles) as well as partnerships between TM4, PSA Peugeot Citroen, Exagon Motors and the Government Du Québec (passenger cars), can be named as recent examples.

The abovementioned profit & loss simulation for a generic supplier can help to highlight the potential from such collaboration strategies: The simulation shows that a reduction of up to one third of development and ramp-up cost are achievable. The assumption behind this is the successful implementation of a development cooperation with a non-competitive partner (see above). The simulation shows that negative returns can almost be avoided and that an overall business model transformation can succeed at a faster pace than in a stand-alone effort. However, besides mitigating costs and risks by collaborating with other companies, governance issues as well as shared ownership of intellectual property need to be considered. An up-front analysis of these possible show-stoppers is crucial.

Fig. 29 – Profit & loss simulation of portfolio shift for generic supplier – consolidated profit view for development cooperation with a non-competitive partner

Development cooperation

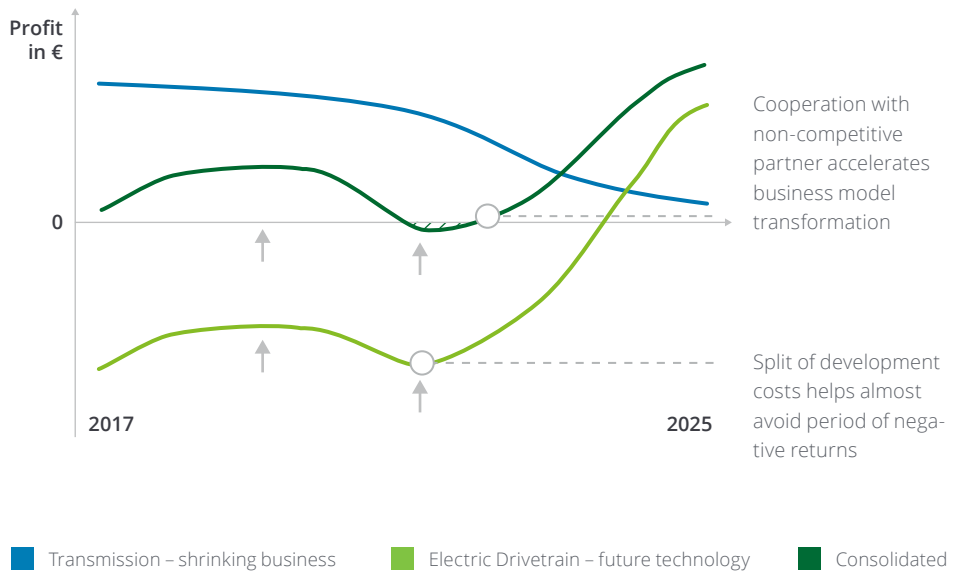

Source: Deloitte AVC Industry Model, Deloitte analysis

In general, two options for such a collaboration can be distinguished: A collaboration between competitors from the same industry, with all the legal questions that come along in this case, especially from cartel authorities; and a collaboration between noncompeting companies across industries. Regarding the first option, surviving in the evolving new automotive ecosystem could mean that competitors in one area may be collaboration partners in others. Flexibility can become a critical condition for participation in specific business areas. The ability to transact through multiple types of commercial relationships will likely become a prerequisite for success, and innovation-oriented collaborative competition becomes the norm. As an example, in 2017 ZF Friedrichshafen AG and HELLA formed a strategic partnership on sensor technology, particularly for front camera systems, imaging, and radar systems. The aim is to further strengthen the ZF portfolio as a system supplier as well as to provide broader market access to HELLA with its innovative technologies.

Regarding the second option, providing innovative solutions outside of classical business models, collaborations with industry-external players become more relevant. For example, the increased integration of software solutions leads to more and more partnerships between conventional software companies on the one hand and traditional automotive suppliers on the other. The collaboration between IBM and Valeo in co-developing embedded software for vehicles in a joint development center is only one example. The technical expertise on both sides is leveraged to invent better solutions than each could do on their own.

Furthermore, the development of supplier-OEM or cross-OEM platforms around key topics like autonomous driving or multi-modal mobility can create new ecosystems and value dynamics. Cooperating on the basis of joint platforms can be the foundation for new revenue streams. Value creation through data and analytics is one of the key elements in supporting new service offerings for suppliers. Capturing, storing, securing, and analyzing product data is the basis for value-added services. Relevant supplier use cases can, for example, be found in the development of autonomous drive features. Suppliers can offer to store sensor data for extended periods of time (e.g. 15 years) and maintain auditing acceptable data repositories for OEMs. Another potential use case can be to process and sell collected sensor data packages so that OEM developers can use them to further improve autonomous drive simulations and quality assurance of features. As the mentioned fields of action are all relatively new, they should be seen as an opportunity for suppliers to reach out in new business fields and build new revenue streams.

Consolidation and scaling strategies

Transformation strategies described in the two previous chapters force companies to venture into new, profitable business fields. Consolidation strategies, on the other hand, attempt to achieve performance leadership in traditional products and locations, despite declining market sizes and profit margins. Prerequisite for this strategy is to ruthlessly drive process and cost efficiency, scale up production capacities, and ultimately become the undisputed partner of choice for the remaining customers in an otherwise shrinking market. This also means pushing remaining competitors out of the market – partly by mergers and acquisitions. However, it requires not only significant funds to be able to act in the merger markets, but also strong management and financial efforts to ensure smooth post-merger integration and exploitation of synergies.

Looking at the projections from the Deloitte AVC Industry Model provides a few examples of component clusters, where the consolidation and scaling strategy can become a viable option. Picking up the example of the generic transmission supplier: With the breakthrough of alternative drivetrains, demand for ICE-related components like transmissions will decrease sharply. However, the remaining ICE and transmission demand (e.g. for niche segments like sports and luxury cars) should still be significant enough to provide profitable business for a selected few German ICE suppliers. OEMs and other mobility customers might even have a strong incentive to support such a plan because otherwise the safety and stability of the transmission supply might become problematic.

If the consolidation and scaling strategy is carried out successfully (see figure 30), financial returns can even enable further investment in new, growing product clusters (as described on pages 50–54).

Fig. 30 – Profit & loss simulation for generic suppliers – consolidation and scaling strategy

Transmission consolidator

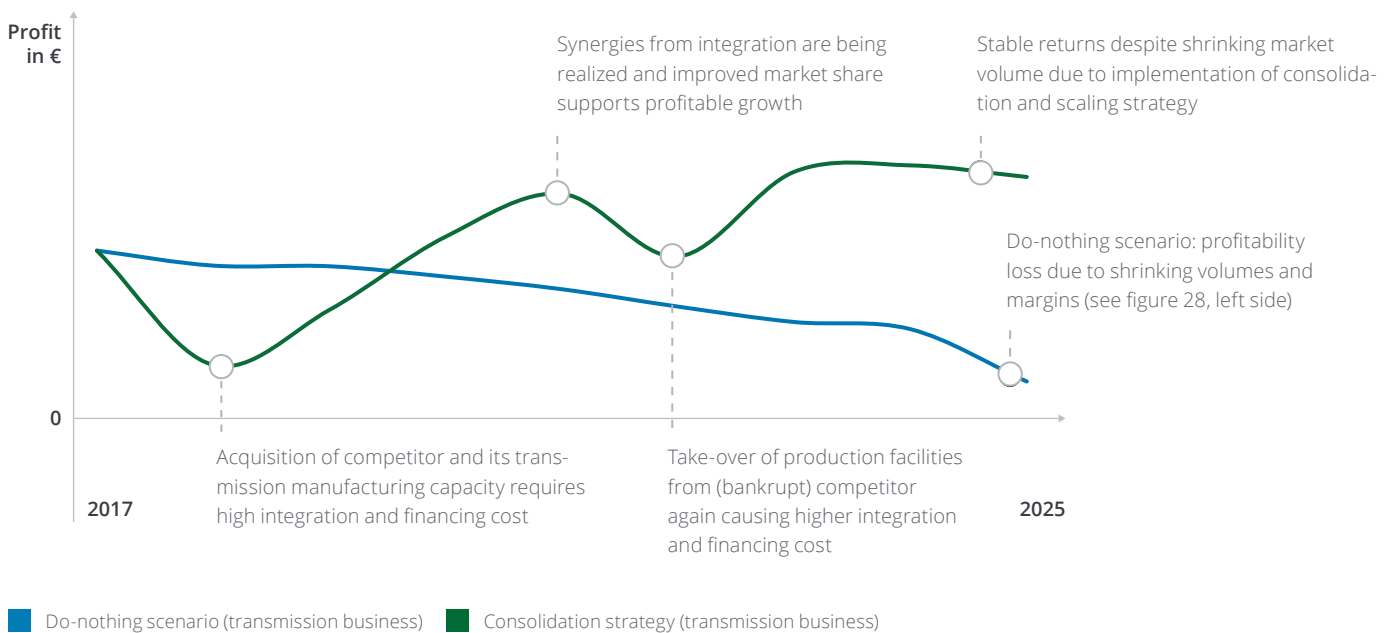

Source: Deloitte AVC Industry Model, Deloitte analysis

Localization strategy review

Shifts in product strategy – as described above – also require high flexibility in a supplier’s localization strategy. Higher complexity of vehicle systems and higher numbers of variants further increase supply chain complexity, drive change and qualification costs, and increase the risk sensitivity of manufacturing plants. A simple framework for integrating and balancing these and other challenges is the localization cost radar (figure 31).

When products and plant production plans change regularly, the underlying materials and services must be available at target locations on short notice. With higher

product complexity and usage of new technologies, the risk increases significantly of ending up with a production plant in a low cost market which does not have access to the required pre-products or services.

The strongest impact happens to the common productivity/labor cost systematic: The specific business case will typically be positive if labor cost savings exceed effects of lower quality or productivity standards. However, the calculation must also consider the slower qualification speed of the workforce as well as lower flexibility. While it is (relatively) simple to change a product in a mature market with generally low rates of labor attrition like Germany or France, it is

more complex and expensive to do so in a low-cost country where knowledge, infrastructure, and change capability have to be imported. In addition, the risk sensitivity of the factory has to be analyzed. With new and more complex products, the requirements on infrastructure, deviation processes, and also the supply chain increase.

Fig. 31 – Localization cost radar

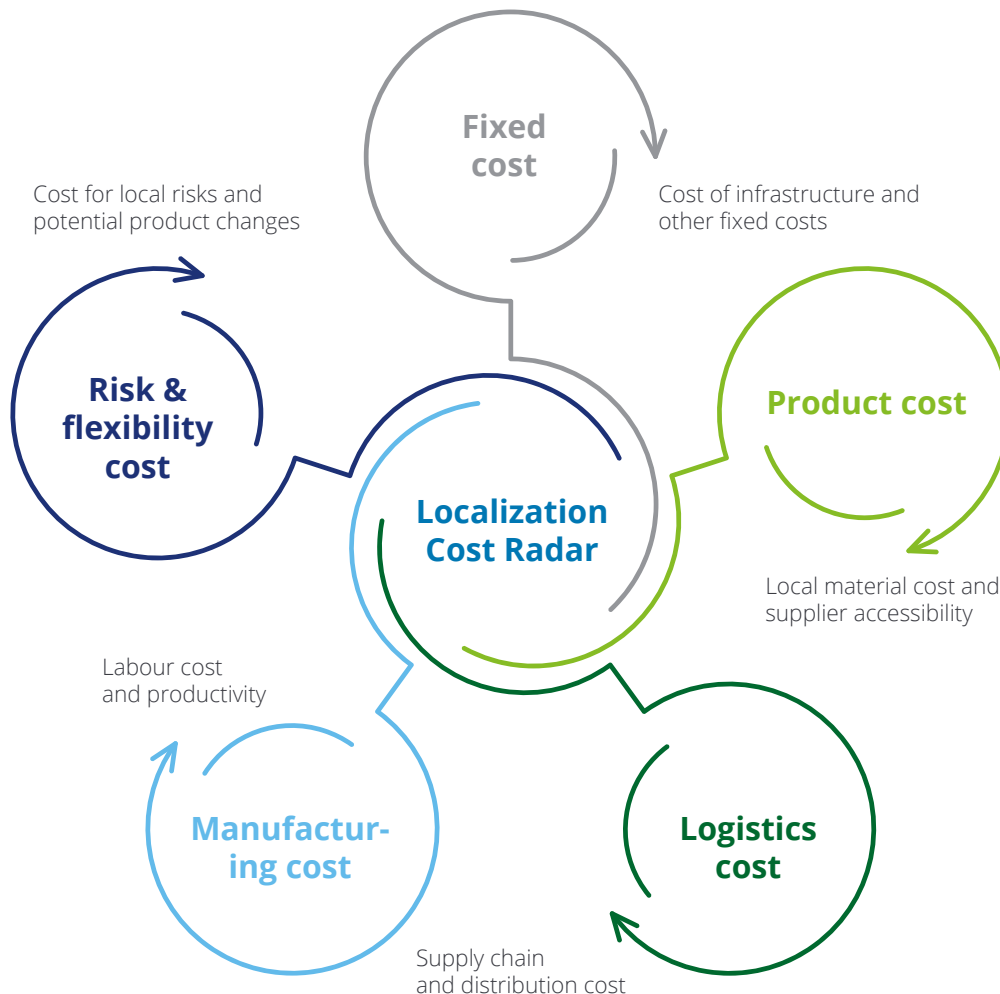

Source: Deloitte Consulting

Digitization drives optimization of traditional core business, which in turn allows companies to invest in new business opportunities

The conflict between the different areas of the localization radar can be highlighted by looking at the transmission suppliers discussed on the previous pages: Based on our model outputs, shrinking transmission market volumes as well as lower profit margins are to be expected. Thus, closer scrutiny of transport costs and opportunities for producing local content close to customer plants must be considered. On the other hand, increasing uncertainty regarding customer (OEM) demands and

stability, sourcing strategies, and political environments increases investment risks significantly. As an example, Ford canceled a \$1.6 billion plant manufacturing project in Mexico due to political pressure, which directly influenced the whole supply base and their bet on a growing customer base. Many suppliers had already started to expand their business in anticipation of the new plant. On the other hand, there are several examples where suppliers followed their OEM customers to their respective growth markets (figure 32).

After choosing a specific location, the key challenge for most players is establishing a robust process framework, especially for low cost locations, that integrates all relevant process areas, including product change and launch processes as well as support and deviation processes. Consistent risk monitoring is the key to success.

Fig. 32 – Selected examples of recent supplier plant manufacturing projects

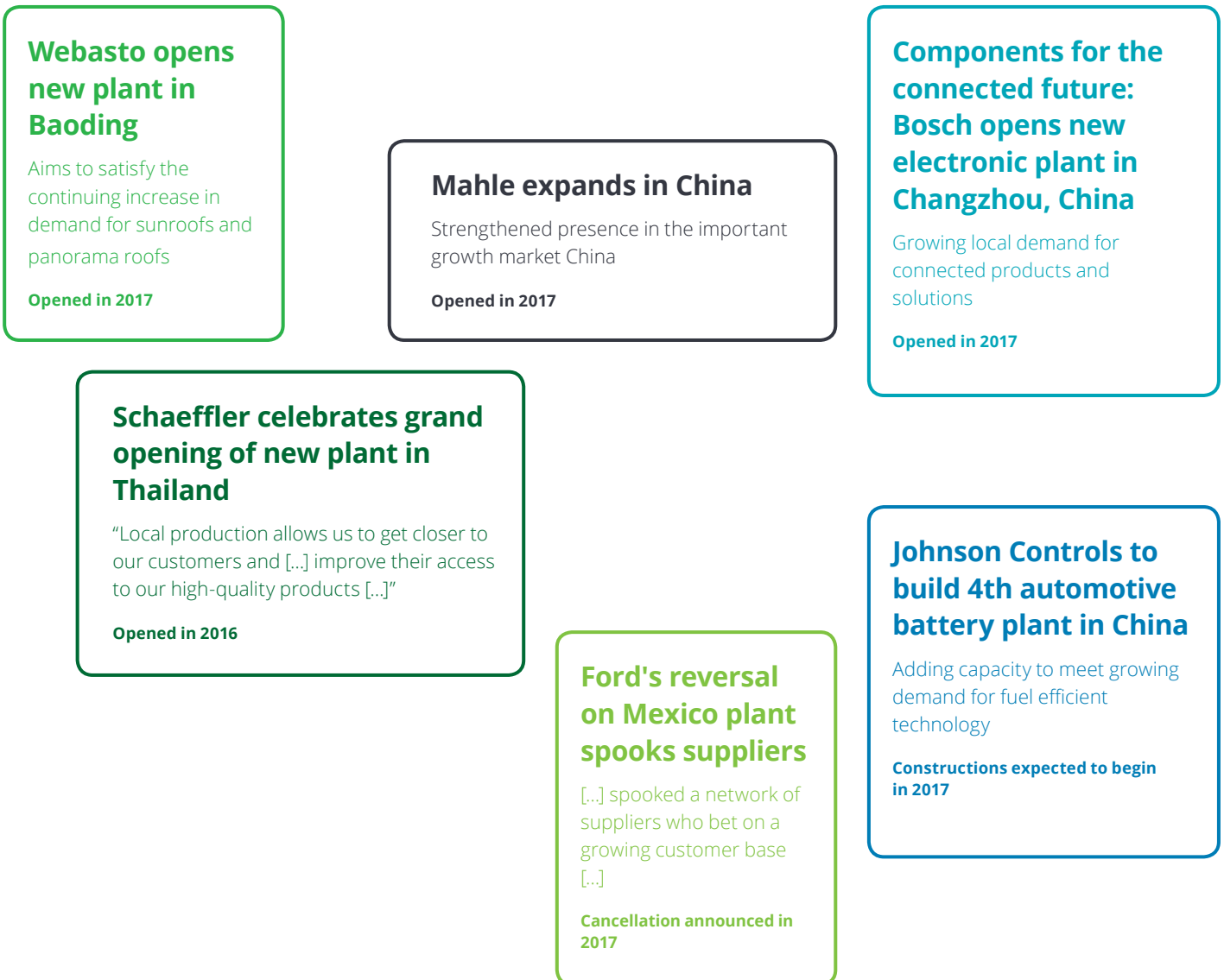

With new and more complex products, the local supplier and manufacturing infrastructure will be tested like never before

Continental selects site in Thailand to build new greenfield tire plant for passenger cars by 2019

"[...] improving the balance of our global manufacturing footprint [...]"

To be built by 2019

Yazaki's automotive wire harness production starts in Serbia

Localization in Europe by establishing a new company

Production started in 2017

Brose expands Mexico presence with new production facility in Querétaro

"Being the first regional site to produce our rear seat structures [...] expand our footprint [...]"

Series production expected to begin in 2018

Digitization for cost leadership

The abovementioned transformation steps put significant levels of financial stress on organizations. Continuously realizing efficiency gains and the resulting cost improvements is crucial along the way. Recent years have seen a rapid rise of use cases for utilizing the potential of so-called Industry 4.0, such as predictive maintenance, data driven demand prediction, or 3D printing. However, many companies fail to fully operationalize these solutions, because they lack an integrated approach. In order to create exponential value through digital transformation, the overall goal is to achieve an integrated concept with combined use cases (figure 33).

As one example, the integrated use of digital use cases for product cost optimization (figure 34) allows for additional savings potential of up to 15% on top of conventional potentials: Specialized scanning tools convert the geometrical layout of parts into digital files, which allow in-depth material cost analysis and optimization. Based on this digital part specification and with the use of a 3D printer, a physical prototype of the cost-optimized part can be manufactured quickly. This method provides an opportunity to significantly reduce both material and production costs, as up to 70% of a product's cost are commonly decided through the design stage.

Fig. 33 – Typical challenges towards the digital transformation

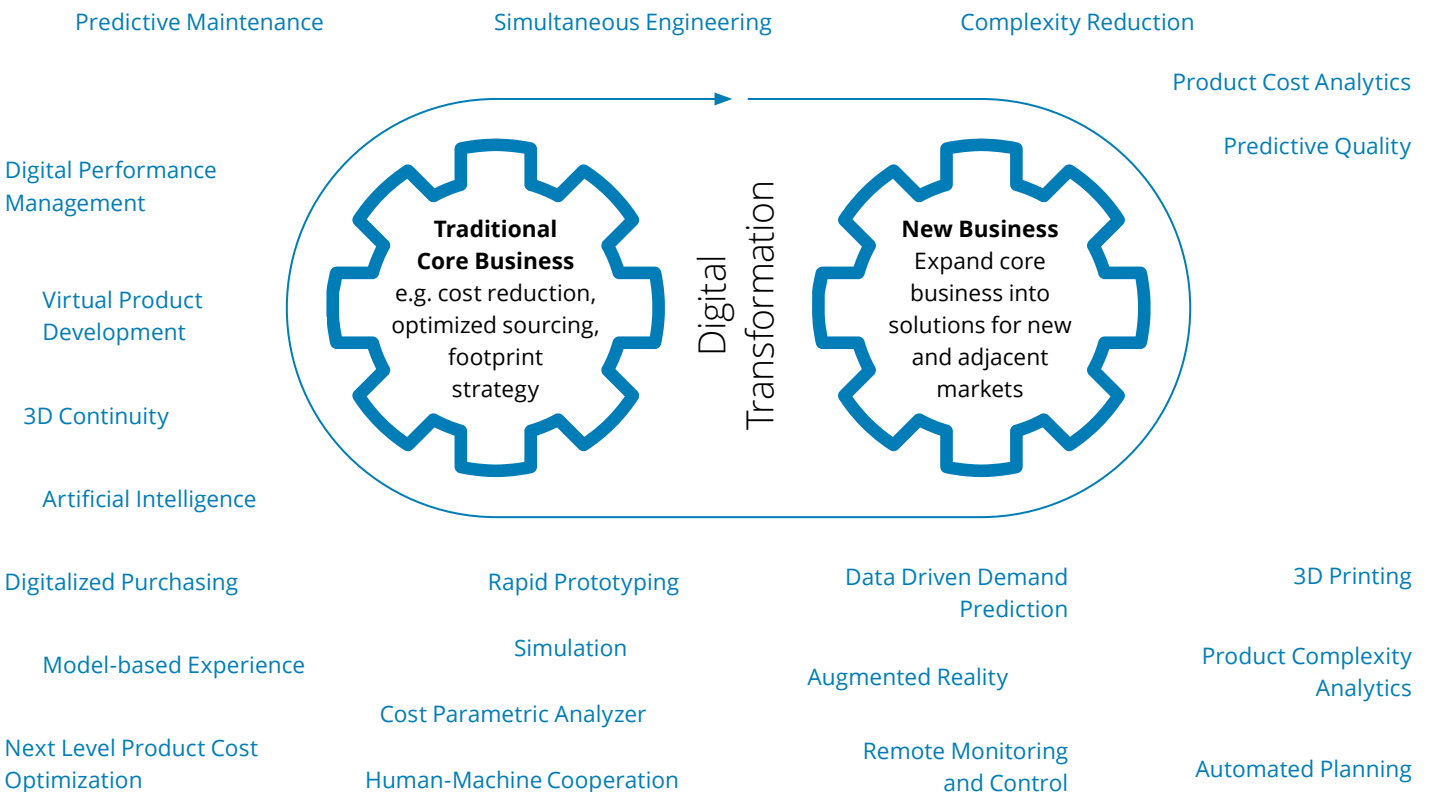

Source: Deloitte Digital Factory

Fig. 34 – Digitization example - integrating digital use cases for product cost optimization to achieve additional savings potential

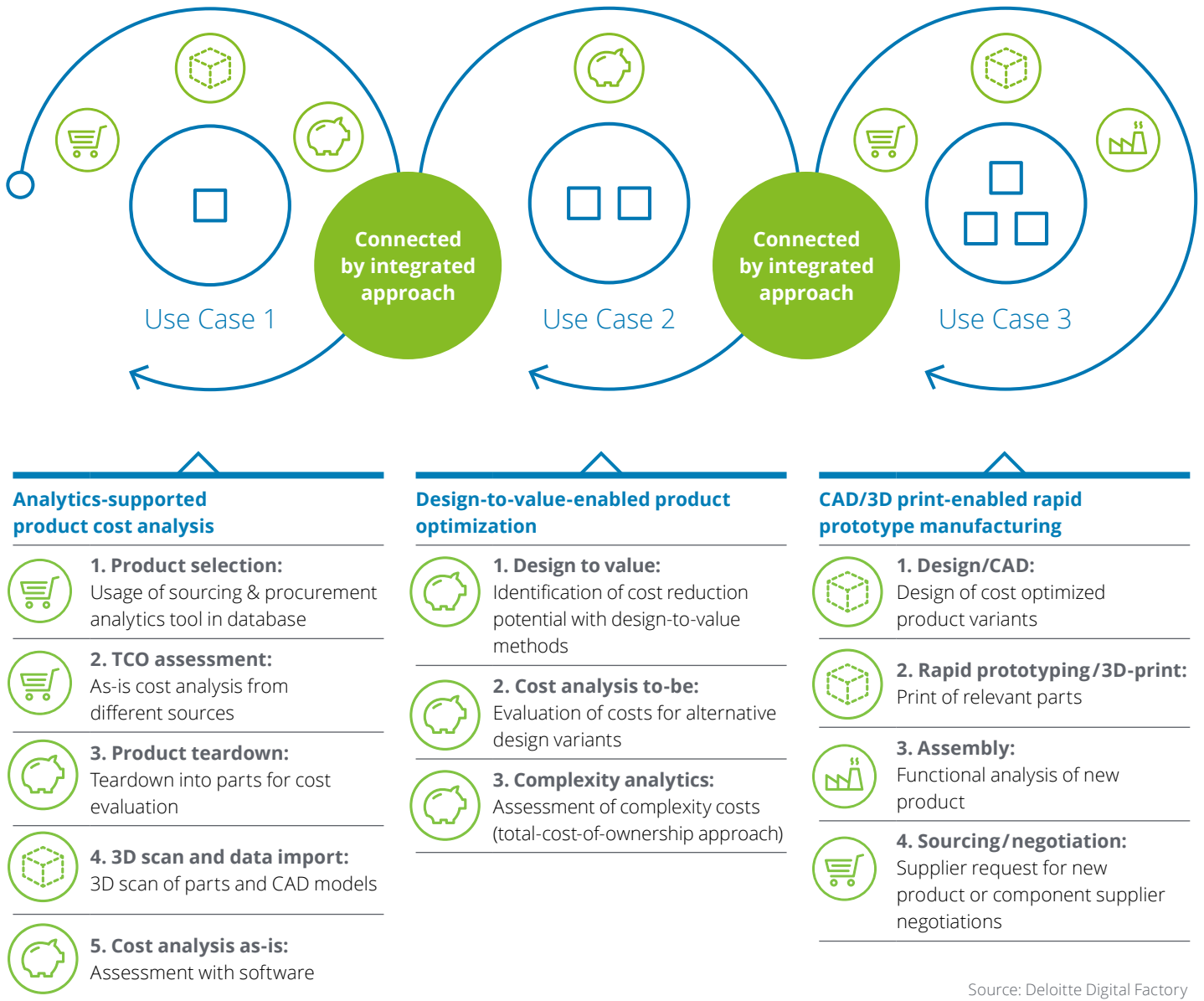

At Deloitte, we have set up a Digital Factory that provides a flexible environment for innovative workshops and training courses. The Deloitte Digital Factory combines a shop floor for product teardown and manufacturing as well as an integrated office floor. Thus, suppliers and other automotive players have the opportunity

to explore live use cases of Industry 4.0 solutions.⁵ All of this serves the strategic purpose of securing financial means from today's profit pools in order to fund for innovation and build new profit pools, as we have exemplified in the P&L simulations for generic transmission suppliers on pages 51 and following.

⁵<https://www2.deloitte.com/de/digital-factory>

Key enabler:

Talent for future business demands

Suppliers develop new business models, alliances, and technologies – like the generic transmission supplier used to exemplify each strategic move throughout this chapter. Forming the future value chain will not only have a significant impact on the number of employees, but especially on job profiles and required qualifications. On the one hand, new roles with adapted abilities arise within the organizations. On the other hand, new organizational structures such as flexible internal talent markets can occur. New dynamic development models, like agile or hybrid-agile methods, require new types of toolsets from employees. The reorientation of organizations will inevitably influence how the current workforce, which has shaped the automotive industry over the past decades, can be successfully integrated and how future talents can be attracted at the same time. The challenge is

to develop a future-oriented talent model, which is designed to attract digital talents in particular. These digital talents require independence and empowerment as well as transparency of their work environment and appreciate a high degree of flexibility. In addition, the new model must also enable the resulting cultural and operational shifts to be reconciled with the needs of the existing organization.

Integrating new types of employees and skills into existing organizational structures is a major challenge. The human resources organization plays a decisive role in this process. A new workforce planning mindset has to be established. Due to new requirements from evolving technologies such as robotics, artificial intelligence, or data analytics, a forecast of the required abilities of the employees is only possible based on long-term thinking which takes into account:

- how future technologies affect the way in which work is done
- when the new skills are needed within the organization
- and in which areas of the organization the change will take place.

This leads to the necessity of a much more flexible model for the organization, which can take changing requirements into account quickly and supports the future of work.

At Deloitte we regularly publish on topics around the future of work. One of the latest examples is the publication “Making the future of mobility work” in the Deloitte Review Issue 21, 2017, “Navigating the future of work”, which gives you a deeper insight into the subject.

Fig. 35 – Talent transformation priorities for future business demand

01

Unleashing networks of teams

Build organizational ecosystems through focused, autonomous, and less hierarchical teams.

02

Rethinking your hierarchy

Revisit the meaning of “career” and what it takes to develop in multi-role, flexible career paths.

03

Developing digital leaders

Develop bold leaders who are comfortable with new tools and management approaches.

04

Pulsing your people

Use internal crowdsourcing and hackathons to collect ideas to build a compelling employee experience.

05

Creating a culture of real-time measurement

Invest in applications that provide real-time metrics on engagement, recruitment, and turnover.

06

Recognizing learning is everyone’s job

Embed learning seamlessly in each part of the organization – through formal and informal knowledge sharing.

From integrated material cost
projections to tailor-made
transformation strategies for
automotive suppliers

Trends, scenarios, and modelling results presented in this study are based on both intensive research and an ongoing discourse with industry experts. As we all know, however, trends in today's automotive world can change dynamically, sometimes even turn around fully, e.g. due to unexpected political interventions on environmental regulation. Therefore, we created the Deloitte AVC Industry Model in such a way that it can be updated regularly and adjusted to specific product portfolio setups.

It is up to individual automotive decision-makers to define and implement their optimal transformation paths towards 2025. The six key strategic priorities represent a set of initiatives that we believe should be assessed in any case, irrespective of scenario, product portfolio and market exposure.

As a tendency, more innovation-driven scenarios (I and IV) might ask for product portfolio shifts, collaboration strategies, and solutions for seeking the talent for future business. On the other hand, scenarios II and III might rather demand digitization as well as consolidation and scaling strategies.

In the end, it is indispensable for any player in the automotive industry to develop quantified and qualified company-specific scenarios. Thus, for the development of individual transformation paths, consistent monitoring of signposts and the consideration of the capabilities of one's own company is of paramount importance.

We, as Deloitte, regularly support such decision making processes: Based on our Deloitte AVC Industry Model as well as integrated strategy and P&L scenario simulation, as shown in the previous chapters. But also, of course, based on many more insights and points of view on the currently immense challenges for the automotive supplier industry.

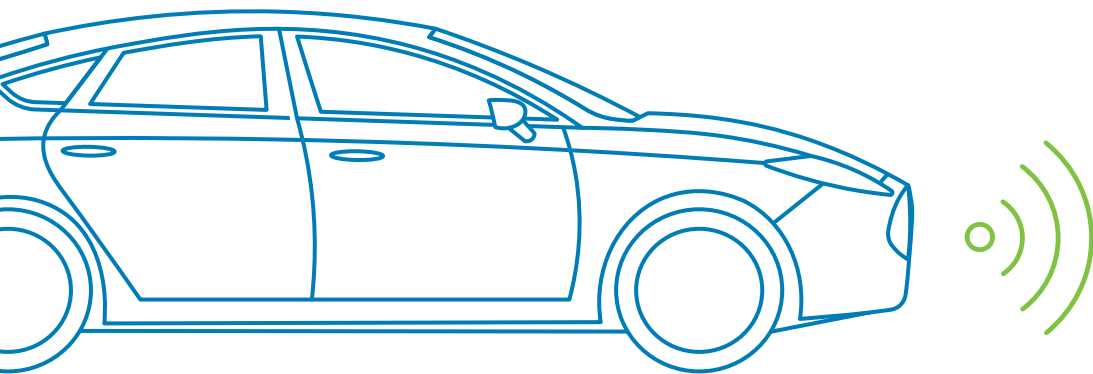

Fig. 36 – Summary: Signature priorities for value chain transformation for automotive suppliers

	Data and mobility manager	Stagnant car maker	The fallen giant	Hardware platform provider
 <p>Product portfolio shifts Match product offering with demand in growing component clusters</p>				
 <p>Collaboration and platform strategies Accelerate developments and share risks through partnerships</p>				
 <p>Consolidation and scaling strategies Seek economies of scale by consolidating volumes of losing component clusters</p>				
 <p>Location strategy review Re-focus production locations according to future market and customer demand</p>				
 <p>Digitization for cost leadership Establish an integrated, digital supply chain for next level cost optimization</p>				
<p>Enabler</p>  <p>Talent for future business demands Create a forward-thinking talent model that considers changing requirements</p>				

Transformation demand
in the automotive supplier
industry is enormous:
Use an integrated market
volume forecasting model
to challenge and develop
strategies

Conclusion

Disruptive changes in the automotive ecosystem will lead to significant transformation demand for automotive suppliers until 2025 and beyond. Results from our AVC Industry Model indicate that

- overall material cost volume in Germany, NAFTA, and China will grow slightly (+6%, not considering spare part business; excluding inflation).
- 15 out of 19 vehicle component clusters will likely see a decline in market volume.
- winners (e.g. electric drivetrains, HV batteries, advanced driver assistance systems) show growth projections of up to 15 times their current volume.
- vehicle component clusters related to the classic ICE vehicle (e.g. transmission, combustion engine or fuel systems) will have to deal with the biggest losses (up to -36%).
- material cost volumes in Germany are facing general decline, while Chinese volumes will increase due to strong vehicle sales forecasts.
- each of these average results, however, must be viewed along their scenario-specific projections (e.g. Infotainment & Communications, which we expect to grow by 25% in one scenario, but decline by almost 60% in another).

These and further modelling results should trigger discussions amongst decision-makers in automotive suppliers regarding re-prioritizing both product portfolios and market exposure. The Deloitte AVC Industry Model can be utilized to compute individual volume projections based on company-specific assumptions in order to challenge existing strategies or to develop alternative ones. In our view, six strategic fields of action should be thoroughly assessed when considering transformation initiatives towards 2025:

- 1. Product portfolio shifts: Match product offering with demand in growing component clusters**
- 2. Collaboration and platform strategies: Accelerate developments and share risks through partnerships**
- 3. Consolidation and scaling strategies: Seek economies of scale by consolidating volumes of losing component clusters**
- 4. Location strategy review: Re-focus production locations according to future market and customer demand**
- 5. Digitization for cost leadership: Establish an integrated digital supply chain for next level cost optimization**
- 6. Talent for future business demands: Create a forward-thinking talent model that considers changing requirements**

Naturally, each company needs to evaluate product-specific material cost volume projections and scenarios according to their individual circumstances and environmental requirements. Derivations of quantified and qualified supplier-specific scenarios lead to a basis for strategic decisions that need to be made in the near future. The high uncertainty forces robust and at the same time flexible options for reacting to short-term changes within the individual transformation path. A constant monitoring of market trends and indications regarding the anticipated scenario will help to actively shape suppliers' future and in a way that plays a significant role in the automotive supply chain of 2025 and beyond.

Authors



Dr Nikolaus Helbig

Partner

Strategy & Operations

Tel: +49 (0)89 29036 7604

nhelbig@deloitte.de



Dr Harald Proff

Partner

Strategy & Operations

Tel: +49 (0)211 8772 3184

hproff@deloitte.de



Matthias Nagl

Senior Manager

Strategy & Operations

Tel: +49 (0)89 29036 7503

mnagl@deloitte.de

Special thanks to Jonas Schnabel, Georg Kempa, Nadja Benzow, Philipp Enderle, Maximilian Rathnow, Eike-Christian Koring, and Alexander Vowinkel for their contributions.

Global Contacts

Joe Vitale

Partner – Automotive Sector Lead Global
jvitale@deloitte.com
Tel: +1 (0)313 324 1120

Dr Thomas Schiller

Partner – Automotive Sector Consulting Lead Global
tschiller@deloitte.de
Tel: +49 (0)89 290 367 836

Damon Cantwell

Partner – Automotive Sector Lead Australia
dacantwell@deloitte.com.au
Tel: +61 (0)396 7175 43

Carlos Eduardo Ayub

Partner – Automotive Sector Lead Brazil
carlosayub@deloitte.com
Tel: +55 (0)115 1861 227

Dr Marco Hecker

Partner – Automotive Sector Lead China
mhecker@deloitte.com.hk
Tel: +85 (0)228 5265 88

Svetlana Fedorova

Director – Automotive Sector Lead CIS
svfedorova@deloittece.com
Tel: +42 (0)246 0439 04

Lars B. Nielsen

Partner – Automotive Sector Lead Denmark
larnielsen@deloitte.dk
Tel: +45 (0)307 037 28

Guillaume Crunelle

Partner – Automotive Sector Lead France
gcrunelle@deloitte.fr
Tel: +33 (0)155 6123 05

Rajeev Singh

Partner – Automotive Sector Lead India
rpsingh@deloitte.com
Tel: +91 (0)124 6792 000

Giorgio Barbieri

Partner – Automotive Sector Lead Italy
gibarbieri@deloitte.it
Tel: +39 (0)115 5972 64

Masato Sase

Partner – Automotive Sector Lead Japan
msase@tohmatu.co.jp
Tel: +81 (0)804 3677 936

Jung Hee Bae

Partner – Automotive Sector Lead Korea
junbae@deloitte.com
Tel: +82 (0)2 6676 3604

Alberto Torrijos

Partner – Automotive Sector Lead Mexico
atorrijos@deloittemx.com
Tel: +52 (0)55 5080 7087

Sharad Mohan Mishra

Executive Director
Automotive Sector Consulting Lead SEA
sharamishra@deloitte.com
Tel: +65 (0)6232 7187

Ruwayda Redfearn

Partner – Automotive Sector Lead South Africa
ruredfearn@deloitte.co.za
Tel: +27 (0)315 6070 74

Jordi Llidó

Partner – Automotive Sector Lead Spain
jllido@deloitte.es
Tel: +34 (0)932 5337 02

Martin Larsson

Partner – Automotive Sector Lead Sweden
martlarsson@deloitte.se
+46 (0)70 080 24 30

Güneş Süsler

Partner – Automotive Sector Lead Turkey
gsusler@deloitte.com
Tel: +90 (0)212 3666 031

Michael Woodward

Partner – Automotive Sector Lead UK
mwoodward@deloitte.co.uk
Tel: +44 (0)207 303 0884

Craig Giffi

Partner – Automotive Sector Lead US
cgiffi@deloitte.com
Tel: +1 (0)216 830 6604

Nordics Contacts

Martin Larsson

Partner

Automotive Sector Lead Nordics

martlarsson@deloitte.se

Tel: +46 (0)70 080 24 30

Daniel Schalander

Senior Manager

Consulting Automotive Lead Sweden

dschalander@deloitte.se

Tel: +46 (0)70 080 47 66



This communication contains general information only not suitable for addressing the particular circumstances of any individual case and is not intended to be used as a basis for commercial decisions or decisions of any other kind. None of Deloitte GmbH Wirtschaftsprüfungsgesellschaft or Deloitte Touche Tohmatsu Limited, its member firms, or their related entities (collectively, the "Deloitte network") is, by means of this communication, rendering professional advice or services. No entity in the Deloitte network shall be responsible for any loss whatsoever sustained by any person who relies on this communication.

Deloitte refers to one or more of Deloitte Touche Tohmatsu Limited, a UK private company limited by guarantee ("DTTL"), its network of member firms, and their related entities. DTTL and each of its member firms are legally separate and independent entities. DTTL (also referred to as "Deloitte Global") does not provide services to clients. Please see www.deloitte.com/de/ueberUns for a more detailed description of DTTL and its member firms.

Deloitte provides audit, risk advisory, tax, financial advisory and consulting services to public and private clients spanning multiple industries; legal advisory services in Germany are provided by Deloitte Legal. With a globally connected network of member firms in more than 150 countries, Deloitte brings world-class capabilities and high-quality service to clients, delivering the insights they need to address their most complex business challenges. Deloitte's approximately 263,900 professionals are committed to making an impact that matters.